



Installation Guide

Micro-dose X-ray Safety Inspection Device ZKX6040

Date: April 2020

Doc Version: 1.0

English

Thank you for choosing our product. Please read the instructions carefully before operation. Follow these instructions to ensure that the product is functioning properly. The images shown in this manual are for illustrative purposes only.



For further details, please visit our Company's website.

Disclaimer

This manual contains information on the operation and maintenance of the specified equipment. The copyright in all the documents, drawings, etc. in relation to the supplied equipment vests in and is the property of the manufacturer. The contents hereof should not be used or shared by the receiver with any third party without express written permission of the manufacturer.

The contents of this manual must be read as a whole before starting the operation and maintenance of the supplied equipment. If any of the content(s) of the manual seems unclear or incomplete, please contact the manufacturer before starting the operation and maintenance of the said equipment.

It is an essential pre-requisite for the satisfactory operation and maintenance that the operating and maintenance personnel are fully familiar with the design and that the said personnel have received thorough training in operating and maintaining the machine/unit/equipment. It is further essential for the safe operation of the machine/unit/equipment that personnel has read, understood and followed the safety instructions contained in the manual.

In case of any conflict between terms and conditions of this manual and the contract specifications, drawings, instruction sheets or any other contract-related documents, the contract conditions/documents shall prevail. The contract specific conditions/documents shall apply in priority.

The manufacturer offers no warranty, guarantee or representation regarding the completeness of any information contained in this manual or any of the amendments made thereto. The manufacturer does not extend the warranty of any kind, including, without limitation, any warranty of design, merchantability or fitness for a particular purpose.

The manufacturer does not assume responsibility for any errors or omissions in the information or documents which are referenced by or linked to this manual. The entire risk as to the results and performance obtained from using the information is assumed by the user.

The manufacturer in no event shall be liable to the user or any third party for any incidental, consequential, indirect, special, or exemplary damages, including, without limitation, loss of business, loss of profits, business interruption, loss of business information or any pecuniary loss, arising out of, in connection with, or relating to the use of the information contained in or referenced by this manual, even if The manufacturer has been advised of the possibility of such damages.

This manual and the information contained therein may include technical, other inaccuracies or typographical errors. ZKTeco periodically changes the information herein which will be incorporated into new additions/amendments to the manual. ZKTeco reserves the right to add, delete, amend or modify the information contained in the manual from time to time in the form of circulars, letters, notes, etc. for better operation and safety of the machine/unit/equipment. The said additions or amendments are meant for improvement /better operations of the machine/unit/equipment and such amendments shall not give any right to claim any compensation or damages under any circumstances.

ZKTeco shall in no way be responsible (i) in case the machine/unit/equipment malfunctions due to any non-compliance of the instructions contained in this manual (ii) in case of operation of the machine/unit/equipment beyond the rate limits (iii) in case of operation of the machine and equipment in conditions different from the prescribed conditions of the manual.

The product will be updated from time to time without prior notice. The latest operation procedures and relevant documents are available on request.

If there is any issue related to the product, please contact us.

About the Manual

This manual introduces the operations of Micro-dose X-ray Safety Inspection Device-ZKX6040.

All figures displayed are for illustration purposes only. Figures in this manual may not be exactly consistent with the actual products.



Document Conventions

Conventions used in this manual are listed below:

GUI Conventions

| For Software | |
|------------------|---|
| Convention | Description |
| Bold font | Used to identify software interface names e.g. OK, Confirm, Cancel |
| > | Multi-level menus are separated by these brackets. For example, File > Create > Folder. |
| For Device | |
| Convention | Description |
| < > | Button or key names for devices. For example, press <OK> |
| [] | Window names, menu items, data table, and field names are inside square brackets. For example, pop up the [New User] window |
| / | Multi-level menus are separated by forwarding slashes. For example, [File/Create/Folder]. |

Symbols

| Convention | Description |
|---|---|
|  | This implies about the notice or pays attention to, in the manual |
|  | The general information which helps in performing the operations faster |



| | |
|---|---|
|  | <p>The information which is significant</p> |
|  | <p>Care taken to avoid danger or mistakes</p> |
|  | <p>The statement or event that warns of something or that serves as a cautionary example.</p> |

Table of Contents

| | | |
|----------|-----------------------------------|-----------|
| 1 | DISASSEMBLY | 9 |
| 2 | RACK CONNECTION | 11 |
| 3 | WIRING | 12 |
| 4 | POWERING ON | 13 |
| 5 | CHECKING THE BAGGAGE | 14 |
| 6 | POWERING OFF | 15 |

1 Disassembly

1. Use the triangular key to open the side panel. Lift the side panel first while removing it. Note that there are two positioning posts under the side panel.
2. Use a wrench to loosen counter-clockwise and remove the four hexagon bolts that fixed inside.
3. Use a wrench to unscrew the four supporting foot cups under the device clockwise to disengage the device from the wooden strip, and then pull out the two supporting wooden strips under the device. Use a wrench to twist the four support feet under the device counter-clockwise until the wheels can move.
4. Move the device to the place of use. Put on the side plates on both sides to cover the device. When closing, pay attention to the cooperation of the positioning posts at the bottom and the holes of the side plates. Finally, twist the foot cup clockwise to ensure the floor support and locks the foot cup nut.

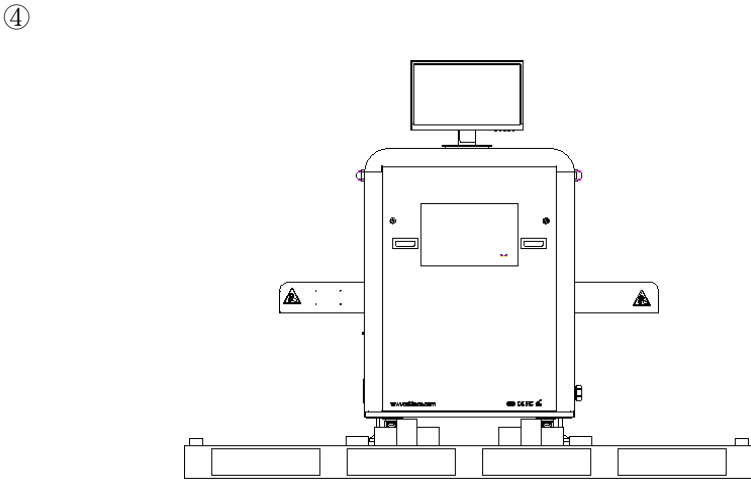
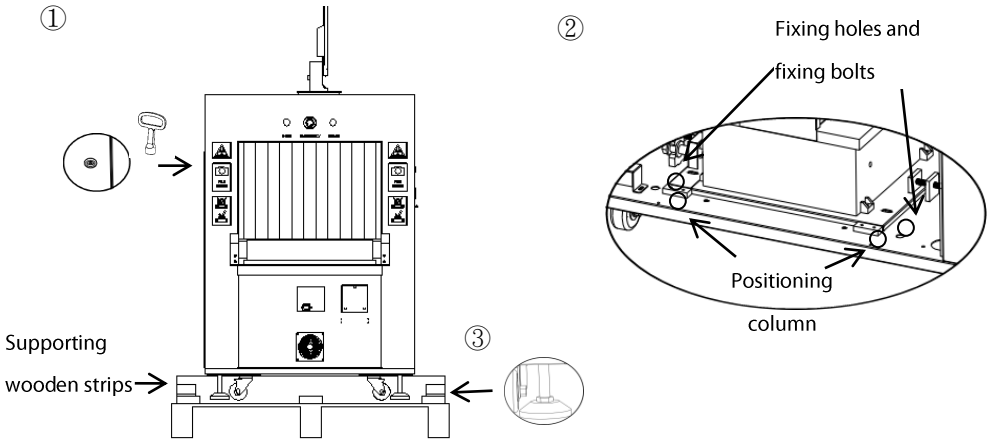

2 Rack Connection

1. Use 8 M6 * 16 cup head hexagon screws with spring pad flat pads to connect the H rack with the object tray.
2. Place the idler roller on the fixed seat of the receiving rack.
3. Use 4 M6 * 16 cup head hex screws to fix the connection piece of the rack to the machine.
4. Use 8 M6 * 16 cup head hexagon screws to connect the object holder.

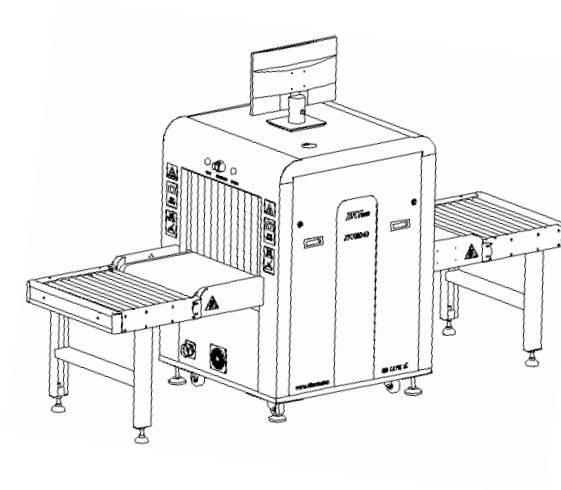
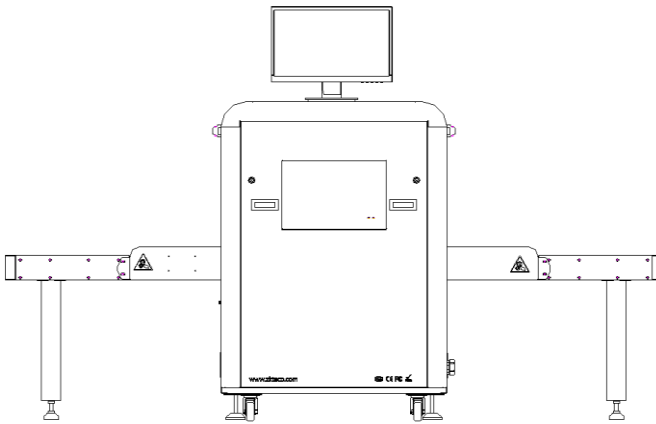

3 Wiring

1. Take the monitor out of the package and install the screen and the base.
2. Connect the VGA cable and the monitor power cable on the safety inspection device board to the monitor.
3. Insert the power cord of the device into the external port of the display device, and then power on.

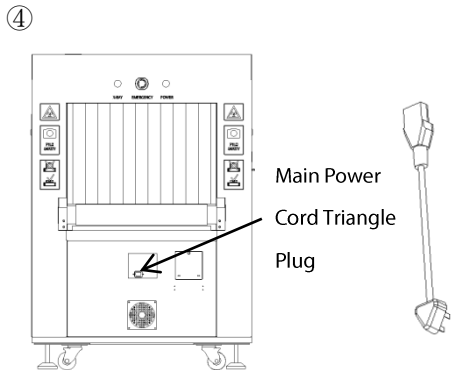
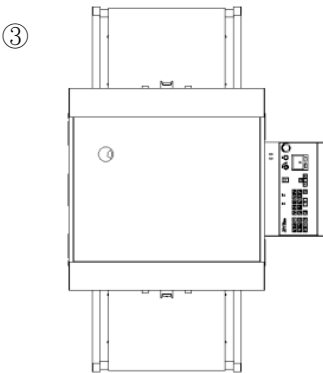
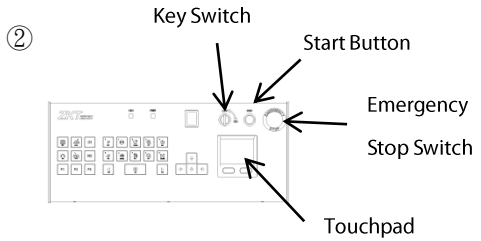
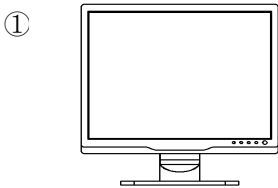

4 Powering On

1. After setting up the wiring, you can use the key to turn the key switch to "ON" and then press the start button next to it and wait for the device to start.
2. Initially, the device logs in automatically as the administrator by default. The default administrator login username and password are:

Username: 9999; **Password:** 123456.

Please change the password as soon as possible after the initial login.

①

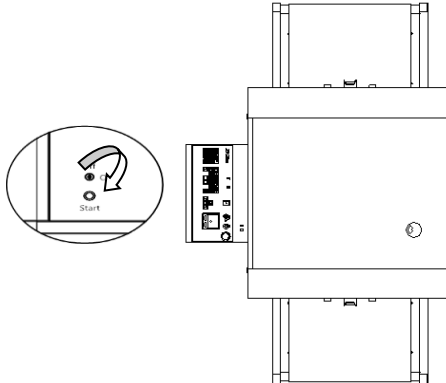

②



5 Checking the Baggage

1. Place the baggage on the belt at the entrance, and use the mouse to click the "Forward" direction key in the motor control button.
2. While the baggage is transmitted to the object rack through the belt, the image appears on the screen in real time, and the image processing function can be reflected in the image.
3. Use the mouse to click the "Stop" button in the motor control button. After the motor stops running, remove the baggage from the rack.

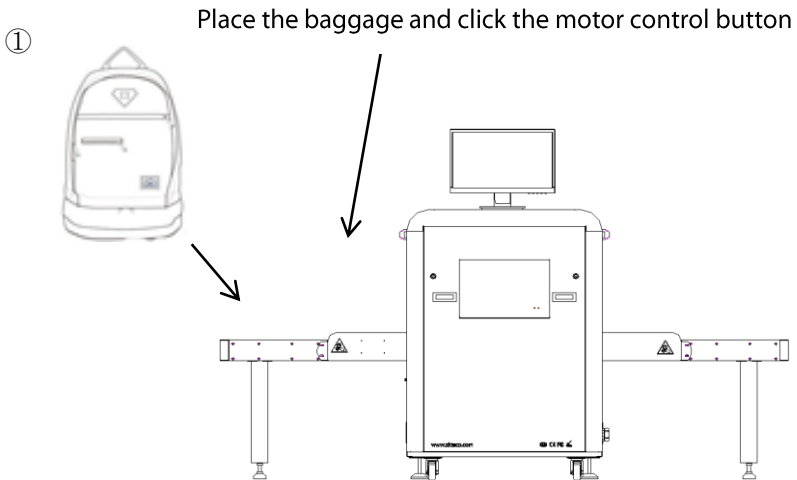

6 Powering Off

1. While powering OFF, you can use the key to turn the key switch from "ON" to "OFF". Note that the device is currently working on storage while being shut down. Do not unplug the power cord of the device.
2. The device will display "Shutdown in progress" and then prompt "Windows will shut down in one minute". When the green (working) indicator goes off, it means that the device is completely turned off.
3. After the device is completely turned off, the commercial power can be directly disconnected. Please take the key on the key switch and keep it safe.

