

PROJECT:

MANUAL ASSISTED VEHICLE BARRIER

SCALE: NTS

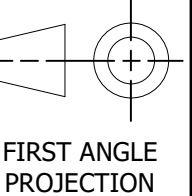

DIMENSIONAL TOLERANCES (UNLESS OTHERWISE SPECIFIED):

FROM:	TO	TOLERANCE
0	25	+- 0.25
26	100	+- 0.50
101	250	+- 1.00
251	500	+- 1.50
501	1000	+- 2.50
1001	>	+- 3.00

APPROVALS:

Drawn By:	BP NEL	2021/03/23
Designed By:	BP NEL	2021/03/23
Checked By:	C SACKS	2021/03/23
Eng Approved:	C SACKS	2021/03/23

MASS:

N/A

MATERIAL:

-

FINISH:

STANDARD FINISH

DESCRIPTION:

3M SPRING ASSISTED OCTAGONAL

PART NUMBER:

MAVB-AS-01

REV:

6

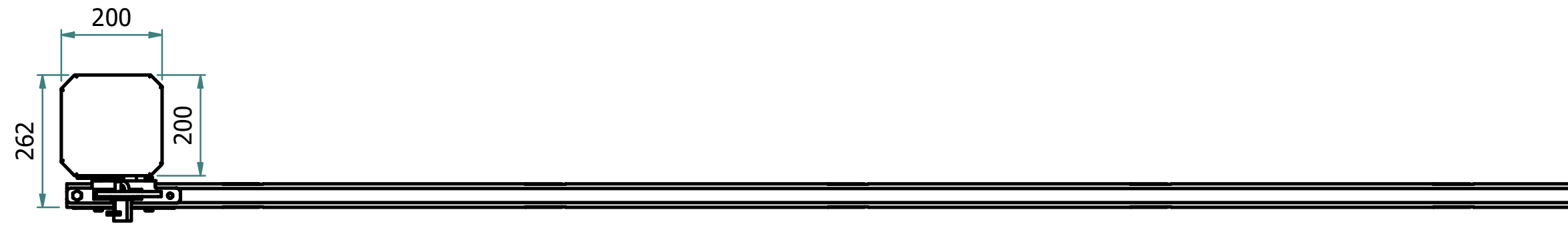

TOP

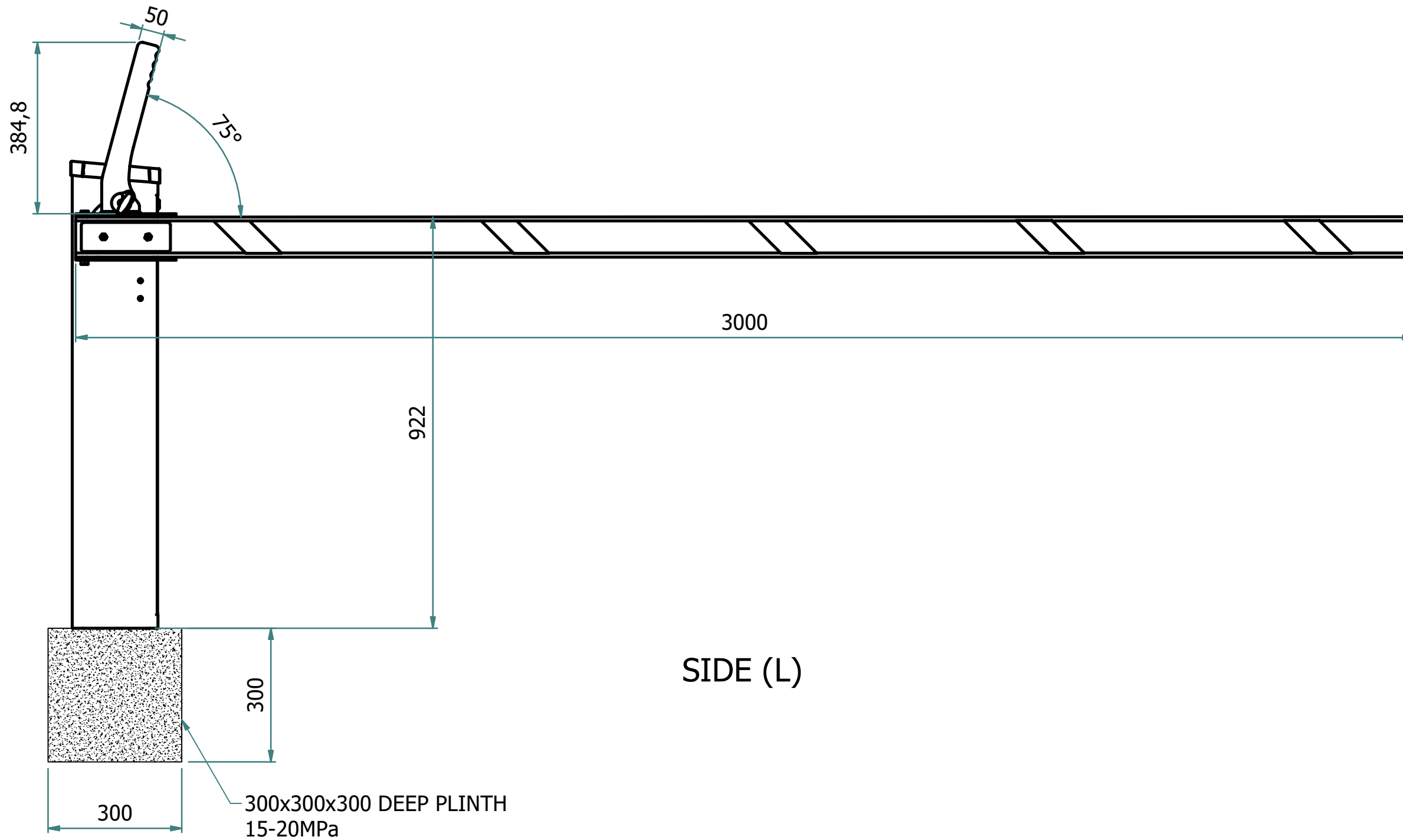

SIDE (L)

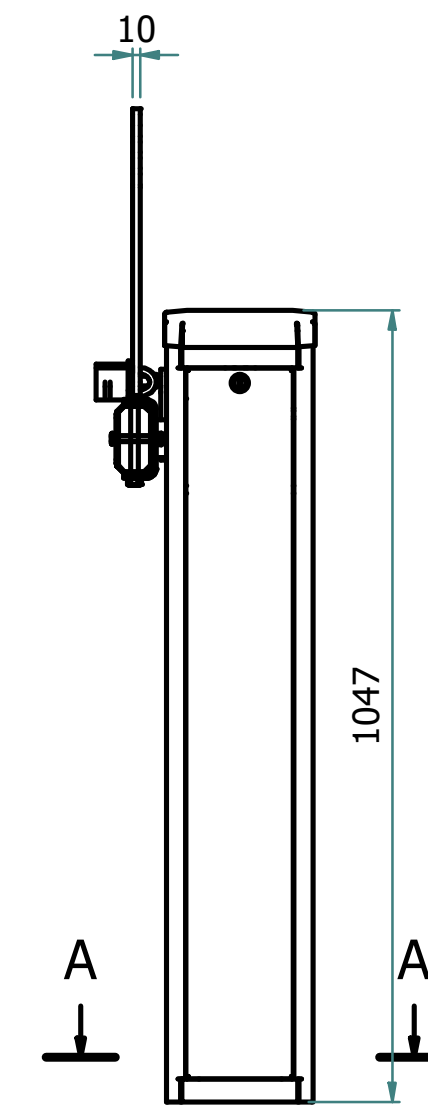

FRONT

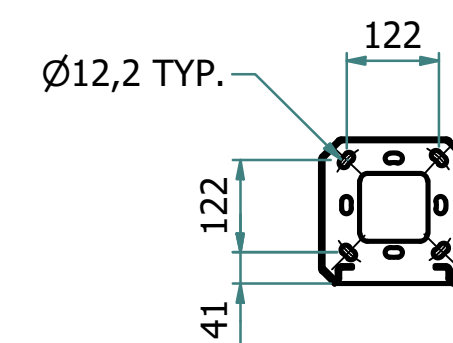

SECTION: A-A

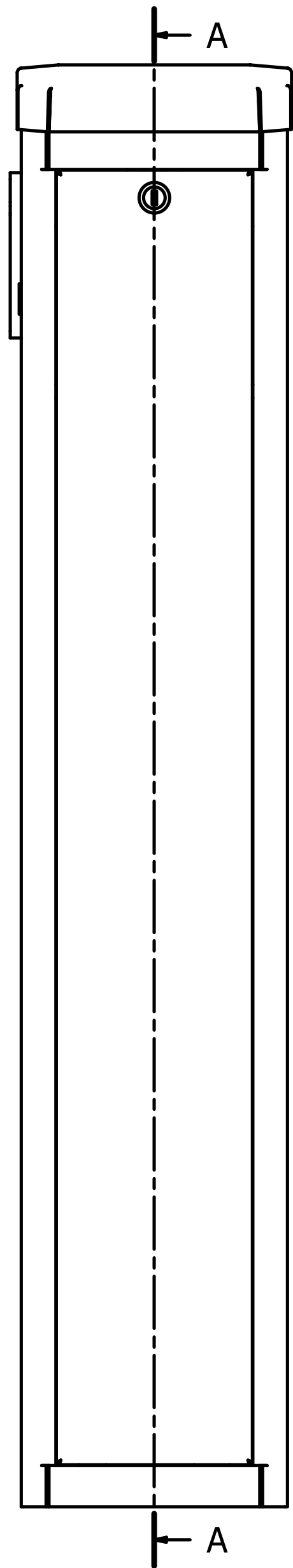

FRONT

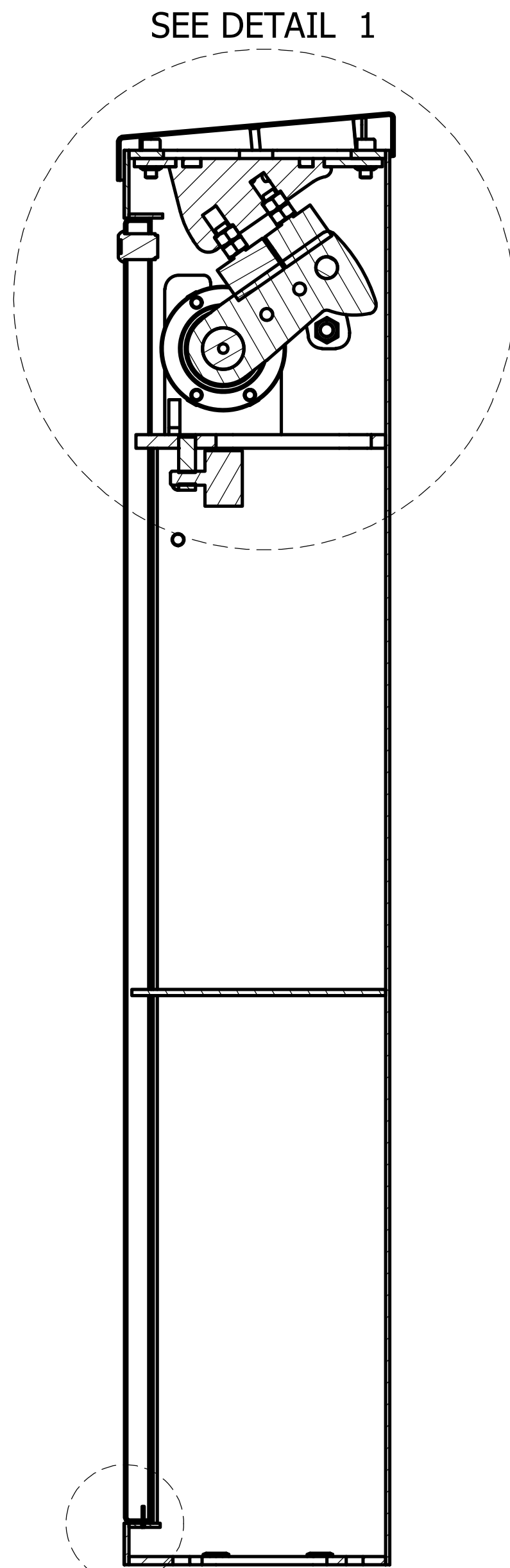

SEE DETAIL 2

SECTION: A-A

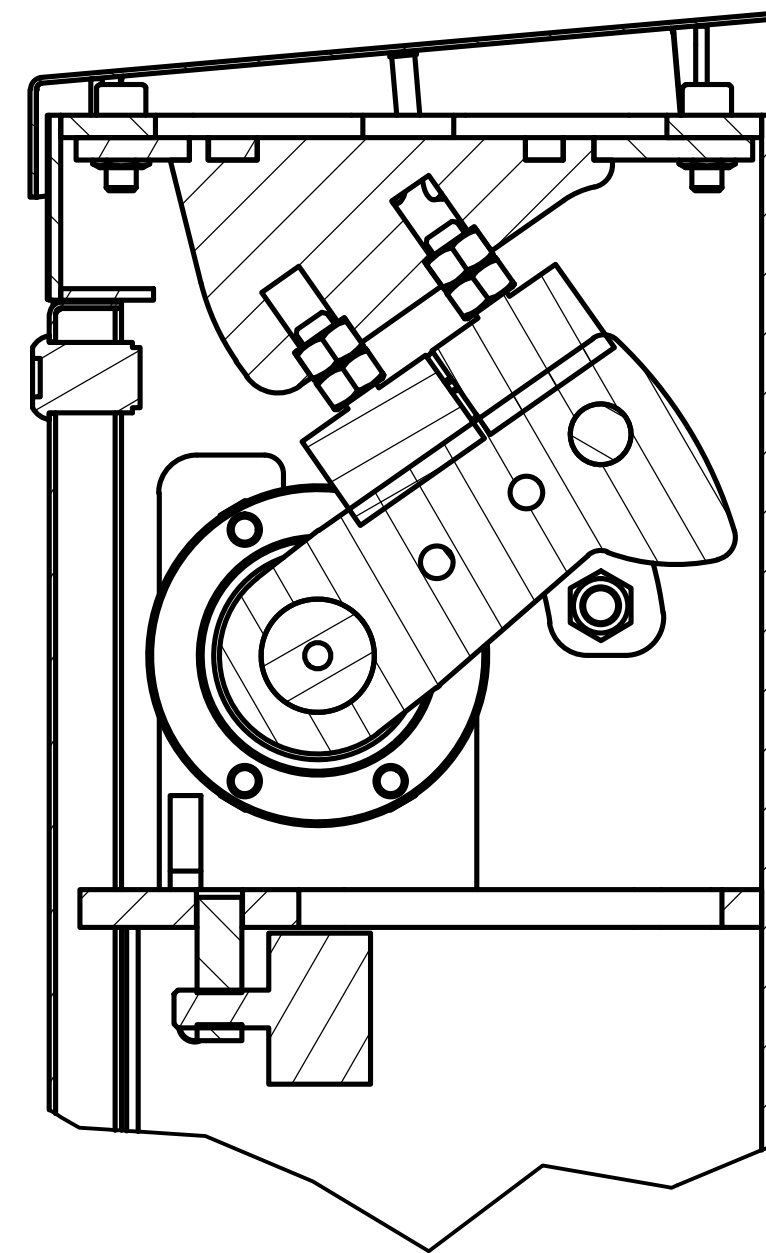

DETAIL: 1
1 : 2

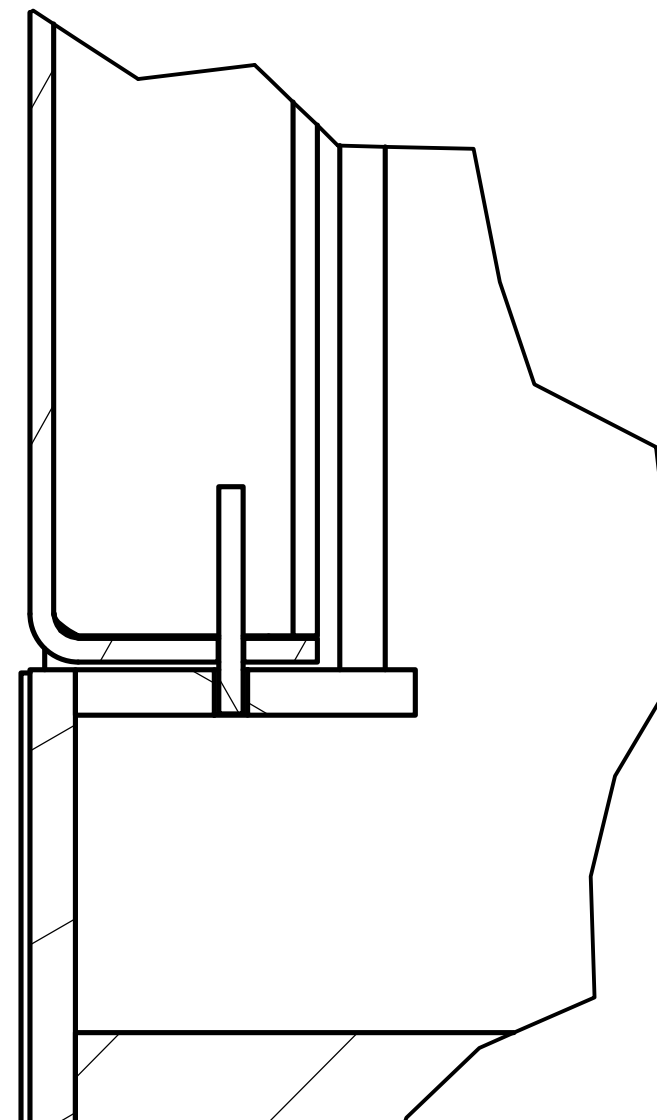

DETAIL: 2
2 : 1

PROJECT:

**MANUAL ASSISTED VEHICLE
BARRIER**

SCALE: NTS

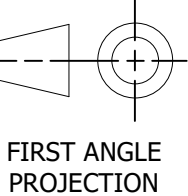

FIRST ANGLE
PROJECTION

DIMENSIONAL TOLERANCES
(UNLESS OTHERWISE SPECIFIED):

FROM:	TO	TOLERANCE
0	25	+- 0.25
26	100	+- 0.50
101	250	+- 1.00
251	500	+- 1.50
501	1000	+- 2.50
1001	>	+- 3.00

APPROVALS:

Drawn By:	BP NEL	2021/03/23
Designed By:	BP NEL	2021/03/23
Checked By:	C SACKS	2021/03/23
Eng Approved:	C SACKS	2021/03/23

MASS:

N/A

MATERIAL:

-

FINISH:

STANDARD FINISH

DESCRIPTION:

**3M SPRING ASSISTED
OCTAGONAL**

PART NUMBER:

MAVB-AS-01

REV:

6