

SUPERMARKET HELICOPTER TURNSTILE

WAIST HEIGHT
UNI-DIRECTIONAL TURNSTILE



SUPERMARKET HELICOPTER TURNSTILE
WITH TURNSTILE SCREEN

CHROME PLATED BARRIER RAILS

APPLICATIONS

- Suited for applications requiring one way free rotating access
- Used extensively in supermarkets and retail stores

DESIGNED FOR

- Interior installations

AVAILABLE CONFIGURATIONS

- Single
- Clockwise and anti-clockwise rotation

SUPERMARKET HELICOPTER TURNSTILE

A	Required opening width	1 450mm	C	Turnstile arm height	900mm
B	Turnstile width	1 411mm	D	Overall height	960mm

ENTRY / EXIT ELEVATION

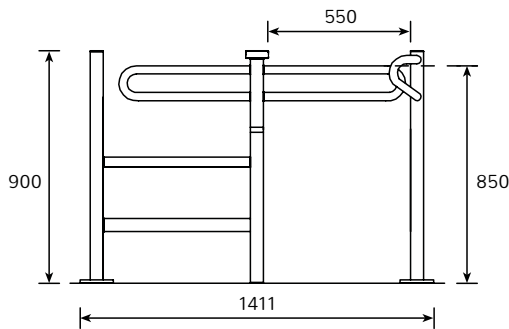

PLAN

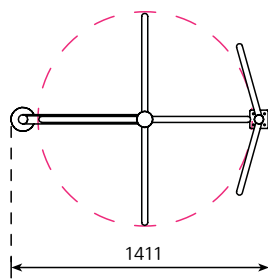

PLAN OPEN (SPECIAL NEEDS AREA)

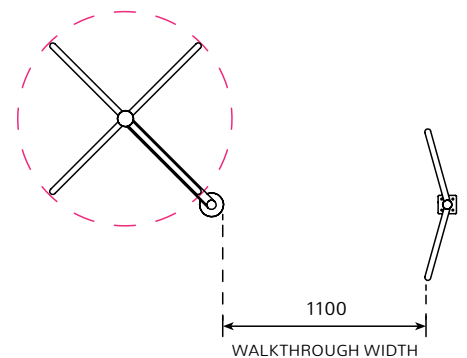

UNIQUE FEATURES

- One way free rotating access. The SUPERMARKET helicopter turnstile is a purely mechanical turnstile and is designed for free rotation either in a clockwise or anti-clockwise direction. The SUPERMARKET helicopter turnstile is not supplied with a locking mechanism or any electronics.
- Centre rotor can be swung out of the way to allow for uninhibited delivery access

MANUFACTURING OPTIONS

TURNSTILE SCREEN

SUPERMARKET helicopter turnstile screen designed to prevent the pedestrian from passing through the turnstile from the wrong way. Available in matching finish to the turnstile.

FINISH OPTIONS FOR THE TURNSTILE AND SCREEN

- Mild steel with UV resistant polyester exterior powder coat finish (white) ■
- 304 grade brushed stainless steel
- 316 grade brushed stainless steel
- other colours available on request

STAR ADDITIONS

BARRIER RAIL OPTION

- 1 500mm long x 900mm high chrome plated barrier rails
- Made-to-fit barrier rails in matching finish to the turnstile

SECURITY GATE OPTION

- Made-to-fit waist height security gate in matching finish to turnstile

TROLLEY ARCH OPTION

- Made-to-fit trolley arch in matching finish to the turnstile for supermarket applications

Due to our policy of continuous improvement, products are subject to change without notice. Custom designs are available on request.