

MST-TX

Tandem Maximum Security Turnstile



Technical Specifications

Dimensions

Unit Height:	91" (2311 mm)
<u>Unit Width:</u>	94.5" (2400mm)
<u>Unit Depth:</u>	54.125" (1375 mm)

Materials

Yokes:
(Curved Sections)

Formed and welded cold rolled steel (or #304 stainless steel). A fully welded, continuous assembly. Consists of 10 pieces of vertically aligned 1 3/4" x 16-gauge tubing notched and welded to two curved, horizontal tubes bent to an inside radius of 28 3/4". Two 3/16" x 1" straps are welded to the outside of the ten tubes for additional support. No external fasteners are used in the construction of the yoke. There are two yokes for each tandem turnstile.

Yoke Guard Plates:

Cold rolled steel (or #304 stainless steel). 16-gauge sheet bolted to the top of the channel / yoke assemblies. There are two yoke guard plates for each tandem turnstile.

Rotos:
(Rotating Sections)

Formed and welded cold rolled steel (or #304 stainless steel). Each arm section of the "standard" roto contains 13 arms for a total of 39 arms per roto, and 12 arms per section for a total of 36 per roto for the "tandem" roto. Each arm is constructed from 1-3/4" OD x 14-gauge tubing, notched and welded to a vertical 3" OD x 3/16" wall tube, and capped with either a 1-3/4" OD x 10-gauge cap (powder coated or stainless steel finish unit) or a force fit, ribbed, plastic cap (galvanized finish unit). No external fasteners are used in the construction of the rotos. All exterior welds are ground smooth and polished. There are two rotos for each tandem turnstile.

OV:
(Barrier Section)

Formed and welded cold rolled steel (or #304 stainless steel). A fully welded and continuous assembly. Consists of 25 arms bent to an inside radius of 28 3/4" and two 2 1/4" OD x 11-gauge vertical tubes. Each arm is constructed from 1 3/4" OD x 16-gauge tubing, notched and welded at each end to the vertical tubes. The OV arms are off set to provide rotation clearance for the respective roto sections. No external fasteners are used in the construction of the OV. All exterior welds are ground smooth and polished.

Top Channel:

Formed and welded 304 stainless steel. The "U" channel is composed of 7" wide 10-gauge steel with a 16-gauge cover. All exterior welds are ground smooth and polished. Houses the main control mechanism components.

All tubing and sheet metal materials meet ASTM Standard A513.

Function

The MST-TX is an electric lock controlled, full height, tandem turnstile designed to provide controlled access into and out of high security facilities in locations where two turnstiles are required, but space for two separate units is not available.

Available Configurations

The MST-TX is designed to interface with virtually any access control system or reader to provide the electric locking control required in controlled access facilities. The following configurations of the MST-TX are available:

- MST-T-3** Using key lock control, each turnstile can be configured to provide free passage in both directions; free passage in one direction and restricted passage (locked) in the opposite direction; or restricted passage (locked) in both directions.
- MST-TX-4X** Each turnstile has electric lock control in one direction, no passage in the opposite direction.
- MST-TX-5X** Each turnstile has electric lock control in one direction, free passage in the opposite direction. This model includes self-centering roto operation.
- MST-TX-6X** Each turnstile has separate electric lock controls in both directions.

Control Mechanism Components

Cam and Shaft Assemblies

The lobed cam of each unit is a precision investment cast stainless steel welded to a splined shaft. The splined shaft fits into a reciprocal splined coupling in the top of each roto, creating a solid non-slip connection between the parts. There are two cam and shaft assemblies for each tandem turnstile, one for the “standard” roto and one for the “tandem” roto. A “standard” cam and shaft assembly is not interchangeable with a “tandem” cam and shaft assembly.

Top Bearing Assemblies

Each cam and shaft assembly rotates in a bearing assembly consisting of two fully protected precision bearings.

Friction Brake Assemblies

The braking mechanism consists of a precision investment cast steel circular disc brake that rotates and maintains contact with two disc brake pads to provide friction braking during the rotation of the turnstile. The friction braking tension is adjustable. There are two friction brake assemblies for each tandem turnstile.

Mechanical Turnstile Control

The locking and unlocking of the unit is controlled with stainless steel lock arms that are moved into the appropriate locked or unlocked position by continuous duty rated solenoids and spring assemblies. There is one solenoid and spring assembly per lock arm, and one lock arm per direction, allowing for independent control of each rotational direction.

Opto Interrupter Rotation Wheel Assembly

This assembly consists of two opto interrupters (small, industrial grade, transmit and receive LEDs), and a rotation wheel. As the turnstile arm is rotated, the rotation wheel passes between the two opto interrupters, signaling the Alvarado Turnstile Controller (ATC) that a turnstile rotation has occurred. The ATC uses this information to re-lock and provide access control functionality without the need for mechanical microswitches. There are two opto interrupter rotation wheel assemblies and two ATCs for each tandem turnstile.

Electrical Components and Functionality

The following are the electrical requirements and standard functionality of the MST-TX:

- Power Supply** 110 VAC, 60 Hz
Low voltage primary power of 10 VAC or 12 VDC may also be supplied by connecting power directly to each ATC.
- Power Rating** Maximum power consumption is 150 W per turnstile.
- Operational Voltage** Primary power is stepped down and rectified for low voltage 12 VDC operation.
- On/Off Switch** An on/off switch is located on each power junction box inside the MST-TX top channel. Two power junction boxes are provided for each electrically controlled turnstile. A visible green LED is illuminated on the ATC when the power is “on”.

Power Receptacles	The power junction box inside the MST-TX top channel includes two 110 VAC power receptacles providing a convenient way for installers or technicians to power tools or equipment they may need as they test or maintain the MST-TX in the field.
Surge Protection	Each ATC has line to line surge protection for single-phase low voltage AC input to 125 amps. Each ATC also contains a varister that switches to a high impedance state to protect the circuit in the event of a power surge.
Bi-directional Solenoid Drivers	Each ATC provides one solenoid driver per rotation direction.
Activation	Activation for either direction of operation is achieved by supplying a momentary dry contact of any duration to the ATC. A terminal strip connection is provided on the ATC for this purpose.
Timed Delay Auto Re-Lock	An activation signal unlocks the turnstile for one entry. Once the turnstile is unlocked, the user is allowed a maximum of 20 seconds to pass through the turnstile. If the turnstile arms are not rotated within the 20-second time frame allowed, the turnstile automatically relocks.
Field Activation Testing	Each ATC provides a field activation testing button, for each electrically controlled direction. This feature provides a simple way for installers to test the functionality of the MST-TX and isolate problems in the field.
Remote Unlocking	Each ATC accepts inputs from a continuous dry contact emitting device to bypass the access control system and allow the MST-TX to be remotely unlocked or "opened" in the electrically controlled direction(s). A terminal strip connection is provided on the ATC for this purpose.
Outputs	Terminal strip connections are provided for the following output signals:
Feedback / Turnstile Rotation Count	The ATC provides a double pole, single throw, relay in each direction of operation. This allows the ATC to provide a "feedback" signal in the form of a relay output to the access control provider or an external counting system. A terminal strip connection is provided on the ATC for this purpose.
Available Finishes	<p>Galvanized All exterior tubing and sheet metal surfaces receive a coating of hot molten zinc meeting ASTM Standards A123 through A153.</p> <p>Powder Coated Available in a wide variety of colors. Sub-assemblies are sand blasted to prepare for the powder coating finish. The powder is electrostatically applied, then baked to assure proper curing and adhesion.</p> <p>Stainless Steel All external fabricated materials are composed of #304 stainless steel (noted in the descriptions above as #304 SS) and polished to a #4 satin finish.</p>
Shipping Details	MST-TX turnstiles are shipped in eight main sections: the Top Channel, the Yoke sections (2), the Rotos (2), the OV, and the Yoke Guard Plates (2). Each section is fully fabricated as a sub-assembly for easy installation. Each MST-TX unit includes mounting hardware (anchors, bolts, washers, etc.) to mount the unit to a standard concrete pad. Alvarado ships products throughout the world.
Installation Details	All MST-TX units must be installed on a firm foundation in a manner that allows the required power and activation signal cabling to be pulled into the top channel. The recommended platform is 102" by 72" by 4" deep, level concrete. No embedded fasteners are needed for installation. Installation should be performed by a skilled installer following the manufacturer's directions and instructions (supplied with the turnstile).
Approximate Weight	Approximately 1,100 lb. (499 Kg) per turnstile.

Options

Failsafe Operation

The electrically controlled direction(s) will unlock upon power loss and provide free passage. The MST-TX unit is supplied in a fail-lock mode as standard. If power is interrupted to a standard fail-lock MST-TX, it will remain locked in the electrically controlled direction(s). Failsafe operation can be specified for one or both electrically controlled directions.

Card Reader Mounting Plate

One or more mounting plate(s) can be provided to allow the access control reader and/or key pad to be mounted on the yoke of the MST-TX turnstile if desired.

Push Button Assembly

This option allows the user to unlock the turnstile for one passage with a stainless steel push button assembly. This option is most commonly used in the exit directions of Model MST-TX-6X units.

Key Overrides

A key override allows the operating technician to override the access control system and unlock one or both directions of the MST-TX turnstile. Key overrides may be either mechanical or electrical (depending on the operation of the turnstile). Separate key overrides are required for each direction of travel and are located on the underside of the top channel. When both directions have key overrides, the locks are keyed alike.

Adjustable Timed Delay Auto Re-Lock

This option allows the operating technician to adjust the duration of the time allowed for the user to pass through the turnstile in each controlled direction. If the turnstile arm is not rotated within the time frame set, the turnstile will automatically re-lock. This option also allows the operating technician to disable the timed delay auto re-lock feature if desired. Adjustments to the timed delay auto re-lock feature can be made in one or both directions for MST-TX units configured to provide bi-directional electric lock control.

Red/Green Card Status Lights

Red and Green LEDs are available for use with the MST-TX unit. The red and green LEDs are configured to function in the following manner:

- An illuminated red light indicates the turnstile is locked and ready for card presentation. The red light will remain illuminated if an “unauthorized” card is presented.
- An illuminated green light indicates that the access system has provided the ATC with an activation indicating that an “authorized” card has been presented. When the green light illuminates, the turnstile will unlock.

Red/Green/Yellow Card Status Lights

Red, Green, and Yellow LEDs are available for use with the MST-TX unit. The red, green, and yellow LEDs are configured to function in the following manner:

- An illuminated yellow light indicates the turnstile is locked and ready for card presentation.
- An illuminated green light indicates that the access system has provided the ATC with an activation indicating that an “authorized” card has been presented. When the green light illuminates, the turnstile will unlock.
- An illuminated red light indicates that the access system has provided the ATC with an activation indicating that an “unauthorized” card has been presented. The turnstile will remain locked. To accommodate this feature an additional terminal strip connection is provided on the ATC for each controlled direction.

Remote Locking

The ATC accepts inputs from a continuous dry contact emitting device to bypass the access control system and allow the MST-TX to be remotely locked or “closed” in the electrically controlled direction(s).

Turnstile Open/Closed Lights

Large Red and Green lights are also available to indicate whether the MST-TX turnstile is open or closed. This option is used in conjunction with the remote locking and unlocking option.

Self-Centering Mechanism

The self-centering mechanism corrects under (less than 120°) or over (more than 120°) rotation of the turnstile arms following completion of a passage cycle. The turnstile arms automatically return to the "home" position (with one set of arms pointing directly at the center of the yoke) when this option is installed. This feature is standard on the MST-TX-5X.

Battery Backup

Two trickle charge battery systems are installed in the top channel to provide turnstile operation if primary power is lost.

Heel Guards

Padded foam sleeves for the lower roto arms. Heel guards are packaged three to a set and are used to cushion the lowest arms on the roto.

Arm Guards

Padded foam sleeves for the higher roto arms. Arm guards are packaged three to a set and are used to cushion the higher sets of arms on the roto.

Computerized Counting

Each turnstile rotation outputs a count to GateWatch, Alvarado's Windows based software program that monitors and records real time patron counts. Counts can be transmitted from the turnstile in several ways, including over a standard, in facility, Ethernet network or using wireless RF devices.

Out of Service Lock Bracket

Enables the turnstile to be secured with a padlock when out of service.

MST-TX Site Preparation

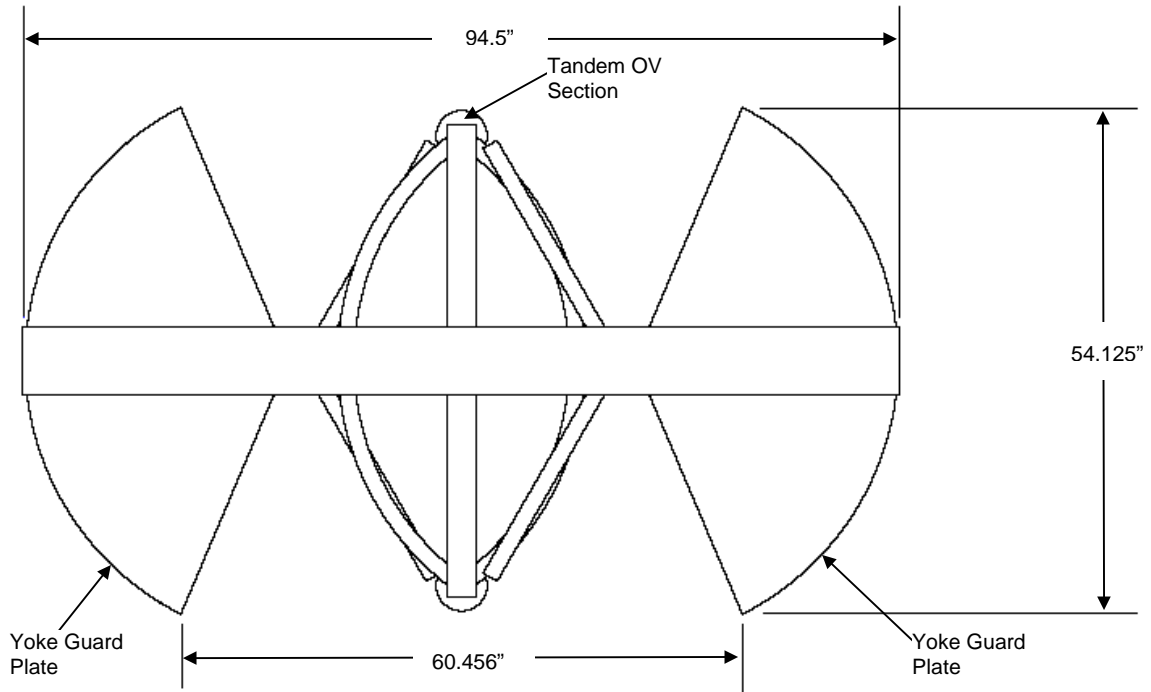
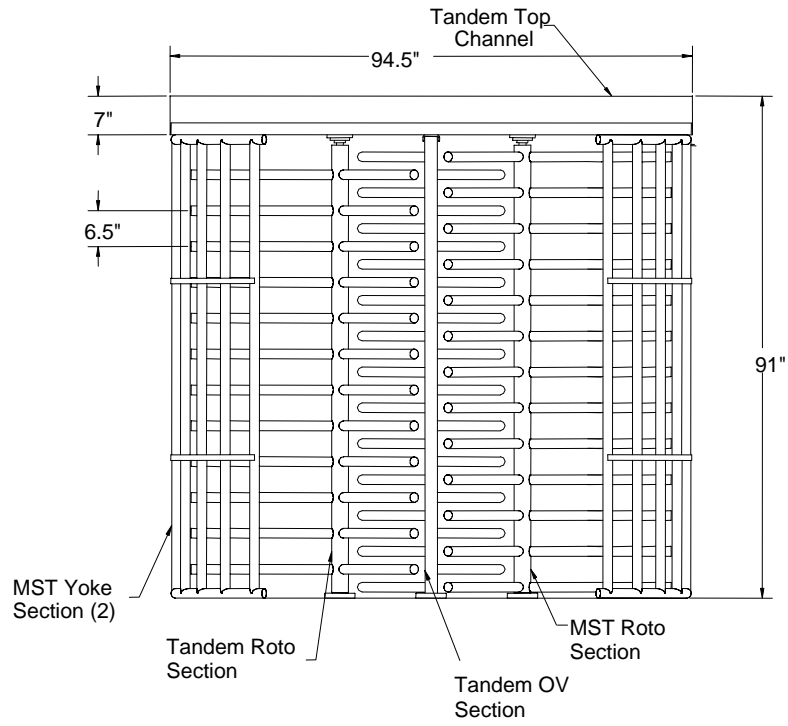

MST-TX Footprint Drawing

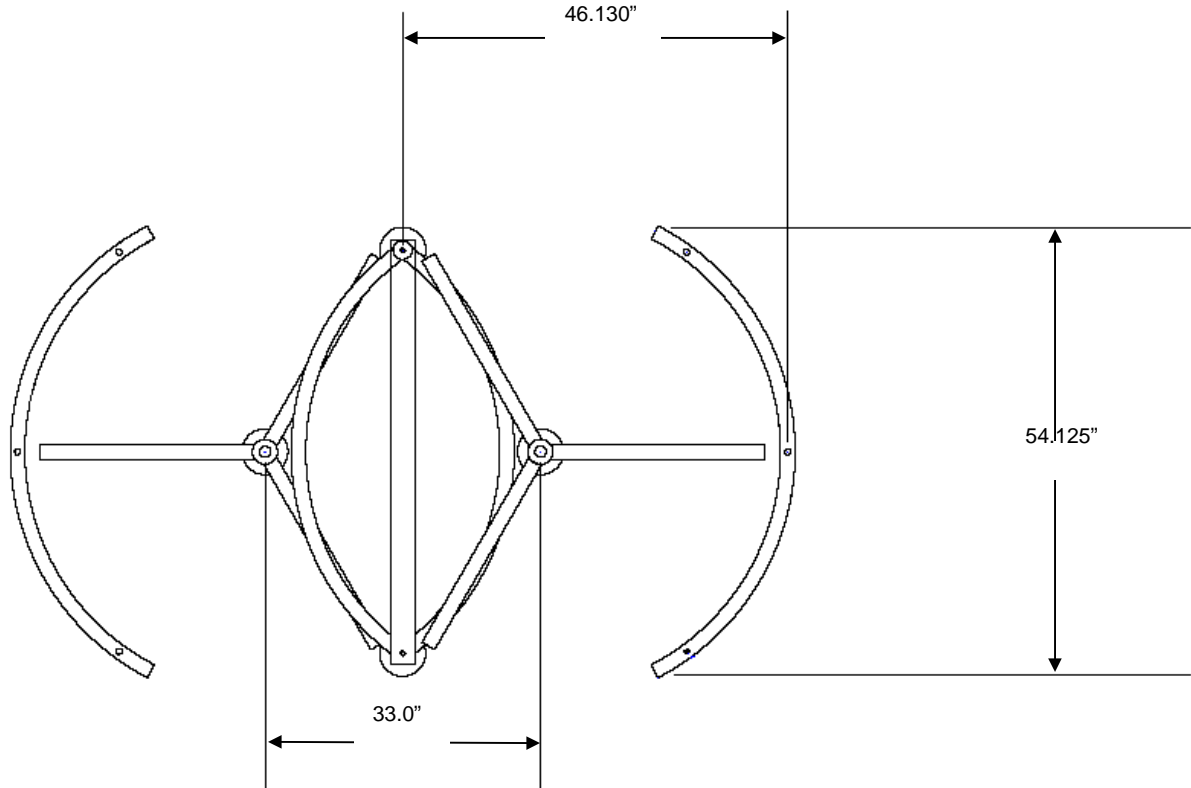

Anchor Pattern

ROTO AND OV BASE

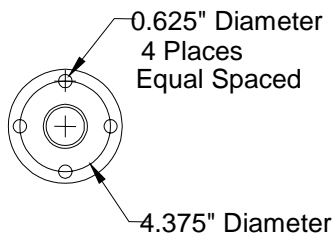

Slab Requirements

- Minimum 102" by 72" by 4" deep, level solid concrete pad

Warranty

www.TURNSTILES.us warrants the MST-TX, from defects in material or workmanship, for the period of ONE YEAR from date of shipment. Complete details of the warranty are available by request.

Technical Services

Technical information is available from www.TURNSTILES.us.

