

Operating Instructions Pedestrian Pivot Barrier Type MPP 122

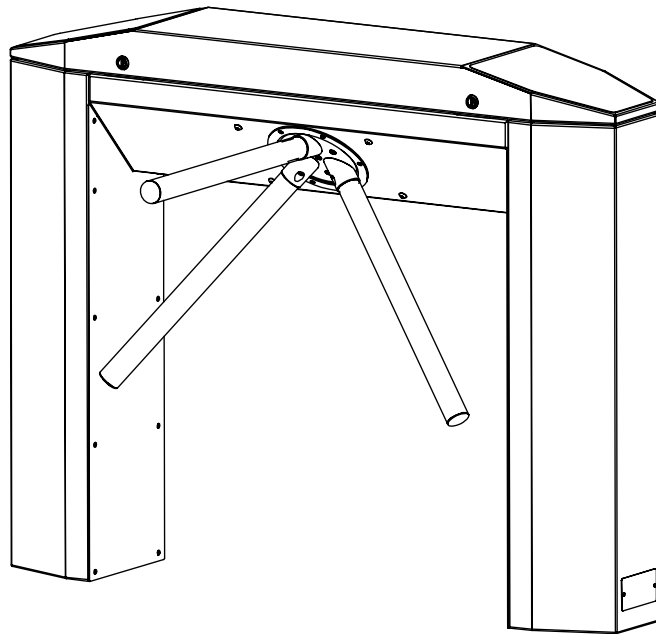

Contents

1.	Delivery	3
2.	Safety	3
3.	Description and Operation	5
4.	Foundation	10
5.	Assembly and Installation	11
6.	Electrical Connection	13
7.	Mounting of Access Control Systems	18
8.	Commissioning	19
9.	Technical Support	19
10.	Spare Parts and Accessories	19
11.	Warranty	20
12.	Operating Instructions MBC-110A-F100 Controller	21
13.	Controller MMC-120-200	34

1. Delivery

1.1 The pedestrian barrier consists of

- 1 x Pivot barrier
- 2 x Fixing anchors complete with dowels and U-profile.
- 2 x Keys for upper housing
- 1 x Set documents

Technical Data:	Type	MPP122
Voltage	VAC	115-240
Frequency	Hz	50-60
Current nominal	mA	250
Current maximal	mA	850
Duty cycle	%	100
Protection	IP	32 /44
Length	mm	1300
Width	mm	260
Height	mm	1035
Weight	Kg	60

2. Safety

2.1 General Safety Notes

The Magnetic pedestrian barrier has been designed, built and tested according to the latest technology. Although it has left the factory in a fully operational and safe condition, it is important that the installation is carried out correctly, therefore the operating instructions must be read carefully and the safety notes must be observed.

Any liability and warranty is declined by the manufacturer in the case of incorrect use and use for purposes other than intended.

2.2 Use for the intended purpose

The Magnetic pedestrian barrier may be used only to control pedestrians entering or exiting restricted areas, usually under surveillance.

The MBC and MMC controllers may be used only for controlling the Magnetic pedestrian barrier. Any other use of the controllers is not permitted. Conversions and modifications to the barrier or to the control module are not permitted.

Only original spare parts and accessories from Magnetic may be used.

2.3 Identification of Risks

Possible risks and notes are identified with the following symbols in the operating instructions:



Warning!

This symbol in the operating instructions identifies actions and conditions which can give rise to danger for life and limb of persons. Observe the instructions carefully.



Caution!

All actions and conditions which can possibly give rise to damage to objects are identified with this symbol in the operating instructions. Observe the instructions carefully.



Note!

Relevant and useful notes for the user are identified with this symbol.

2.4 Safety Notes

- Disconnect all external opening or closing devices (remote control, control desk etc.) during maintenance work.
- It is prohibited to install the barrier without proper mounting to the foundation.
- A main power switch or residual current operated device (e. g. a fuse) is compulsory.
- Documentation should be easily accessible on site.
- Before commissioning make sure all electrical and functional features are tested.
- The electrical wiring of the barrier must comply with the drawings included.
- Only certified and trained electrical technicians may perform the electrical connections.
- Only certified and trained electrical technicians may remove covers for mains plug, mains receivers or wirings.
- Before repairing electrical failures disconnect fuse.
- After return of power the barrier turns automatically to its home position.

3. Description and Operation

The MPP122 pivot barrier is designed to control pedestrians entering or exiting restricted areas, usually under surveillance, in low security situations. The operation of the barrier allows for controlled two directional pedestrian flow and is capable of blocking in either direction, or free rotation in either direction. This model can be used in two directional control applications with high usage of pedestrian traffic such as access control at passenger terminals and sport stadiums etc.

The construction consists of a center housing connected to two end modules. The center housing has a dust / waterproof hinged locked cover providing easy access to the controllers and electromechanical drive mechanism.

Various optional access control devices (such as card readers, finger print readers etc.) can be accommodated at both ends of the barrier.

Optional: A cover with removable facial panels either made of stainless steel or a synthetic material) for a convenient assembly of access control devices is available on request.

The pivot barrier design is available in two versions:

Version 1

Standard type for indoor installations

Polished steel plate 430 stainless steel with protection class IP32

Version 2

Special version for outdoor installations

Polished steel plate 316L stainless steel with protection class IP44 (can be operated outdoor; no roofing required)

The pedestrian pivot barrier is operated by the Magnetic High Torque Motor MHTM with sensor technology and controlled by the MBC controller.

Operating Instructions

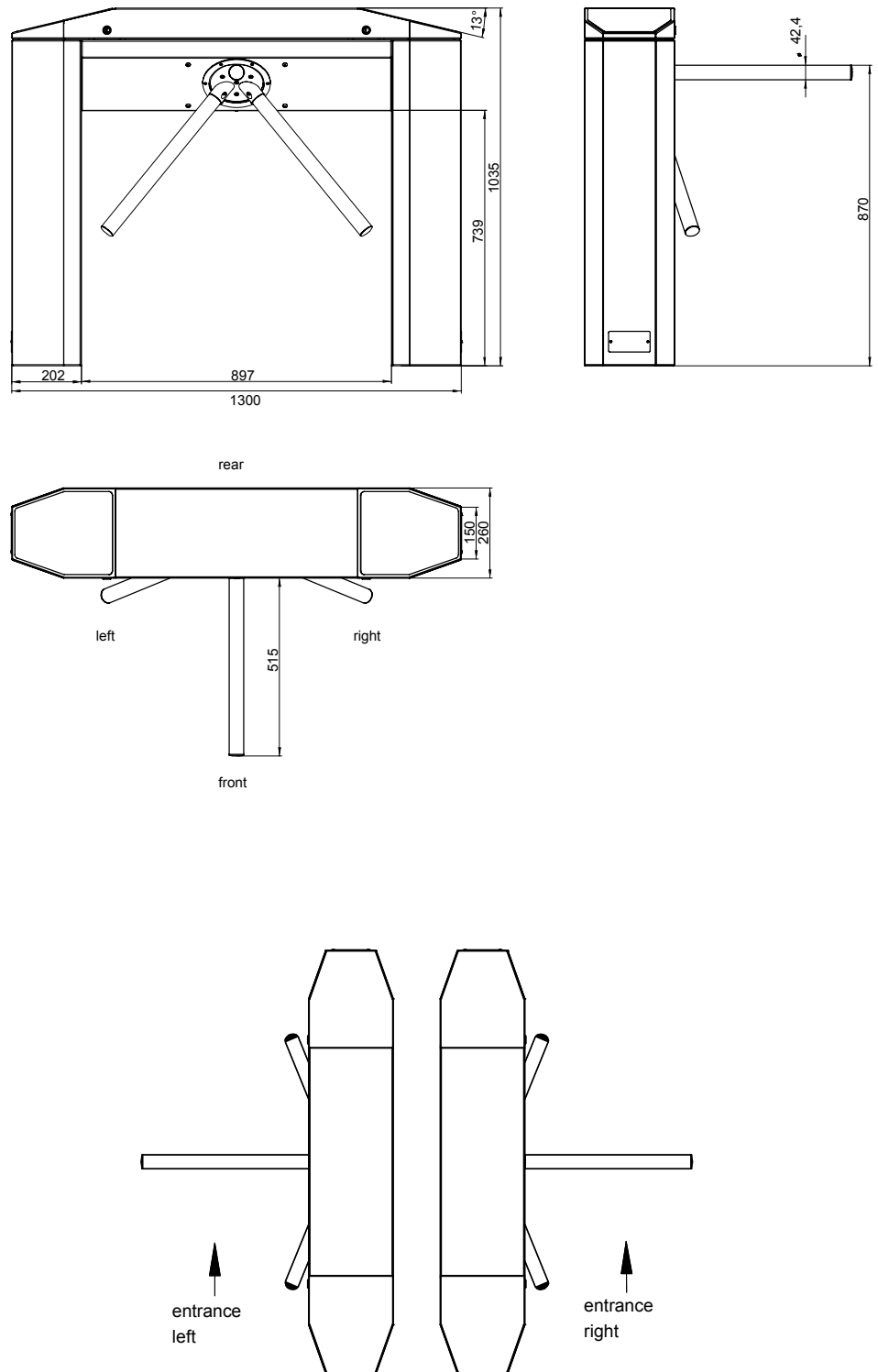

Fig. 1

3.1 Functional Description of the MPP with MHTM with /without Drop Arm

3.1.1 Unpowered State

In unpowered state, the lock is released and allows free rotation of the capstan containing the three turnstile arms. In case of a drop arm mechanism is used, the drop arm will turn down and free passage is allowed.

3.1.2 Learning of Home Position

Before initial start up of the controller or after replacing either the motor or the controller, the home position must be aligned to the controller.

Please proceed as follows:

Make sure, that the power is OFF. Then set the DIP switch 8 "home position" ON. When the power is switched on, the controller automatically selects operation mode "Learning Home Position". The user is requested to confirm "home position" by means of a buzzer and the 7 digits display. During a period of about 10 seconds the buzzer sends warning beeps in intervals that become shorter and finally end in a permanent beep of about 5 seconds. The turnstile arm must be positioned in the desired final position during this time period. The home position will be automatically accepted for default at expire of the permanent beep after totally 15 seconds. This method allows to align the home position without being next to the controller.

For permanent storage of this position, the DIP switch "home position" must be set in OFF position. Storage will be confirmed via a buzzer and the 7 digits display.

For safety reasons, the controller starts only after power is switched off and on again.

3.1.3 Start-up Routine without Drop Arm

The pedestrian pivot makes a homing, i. e. it takes the shortest way to find a home position with reduced speed und reduced torque. During this rotation, a warning signal sounds.

3.1.4 Start-up Routine with Drop Arm

The pedestrian pivot makes a homing, i. e. it takes the shortest way to find a home position with reduced speed und reduced torque. During this rotation, a warning signal sounds. The released drop arm will automatically return to its position.

3.1.5 Standard 120° Operation

After receipt of a release pulse for one direction the pedestrian barrier is released for one direction, the motor holds the pivot arm in the home position with low torque.

The controller expects now, that the pivot arm is pushed forward of minimum 1 - 2° in passage direction by a user. After this, the motor will be normally energized and turns to the next home position (120°).

3.1.6 Bi-directional Operation via Pulses without Pulse Storage

If no permanent signal is activated at both opening inputs, the controller is in bi-directional operation via pulses.

Via a RH or LH input pulse, the aisle can be bi-directional released for one passage in each case. As soon as one of the both pulse inputs has been activated by a request pulse, the so called hold open time starts to count down. At the same time, the corresponding output "display free passage LH /respectively RH" indicates, that passage in the released direction can start. The display output of the opposite passage direction remains locked. This allows to indicate the released passage direction either via a green signal lamp or via red /green displays.

If there is no pedestrian entering the passage in due time, the aisle will be blocked in this direction after count down of the hold open time.

With this operating mode, a new request for passage in the opposite direction will be ignored as long as the turnstile is already released in one direction.

The duration of the pulse has to be 200 - 400 ms

3.1.7 Bi-directional Operation via Pulses with Pulse Storage

This operating mode works similar to the bi-directional operation via pulses without pulse storage (3.1.6), but however, it can be stored up to 5 opening pulses for each direction and then processed one after the other.

The duration of the pulse has to be 200 - 400 ms.

3.1.8 Bi-directional Operation Permanent Open

In case of a permanent signal (>5 s) is activated at both opening inputs, the controller is in bi-directional operation mode permanent open. This means, that the passage is released in both directions, hence, an opening pulse is not required.

3.1.9 Pulse Operation in One Direction, Permanent Open in the Other Direction

If a permanent opening signal is pending at only one opening input (LH /RH), the passage is free in this direction. The other direction remains in pulse operation.

If a release in pulse direction is given, the permanent open passage will be locked immediately. The permanent open operation will be re-activated not before expire of the hold open time.

3.2 Special Cases during 120° Operation

3.2.1 Stop during Motion

In case the turnstile arm is stopped during the 120° operation, probably because of a passenger stops going, the motor tries to continue the operation but with a minimum torque. At the same time, the emergency exit will be activated.

3.2.2 Wrong Direction During Passage

In case of an attempt to return the turnstile arm into wrong direction during passage, the brake will be activated. After a pause the brake will be released and the turnstile tries to continue the operation.

3.2.3 Wrong Direction

In case of an attempt to move the turnstile arm into wrong direction after release via pulse (out of the home position) the brake will be activated. After a pause the brake will be released and the misalignment of the arm adjusted.

3.2.4 Vandalism

In case of an attempt to move the turnstile arm into wrong direction without release (out of the home position) the brake will be activated. After a pause the brake will be released and the misalignment of the arm adjusted.

3.2.5 Emergency

If input IN4 "emergency" is interrupted, bi-directional free passage is released respectively the drop arm will turn down.

If IN4 is reactivated, the turnstile moves to home position (inclusive automatic drop arm reset).

4. Foundation

A level concrete mounting surface is required to secure the barrier housing. Refer to Fig. 2 if a concrete foundation is required.

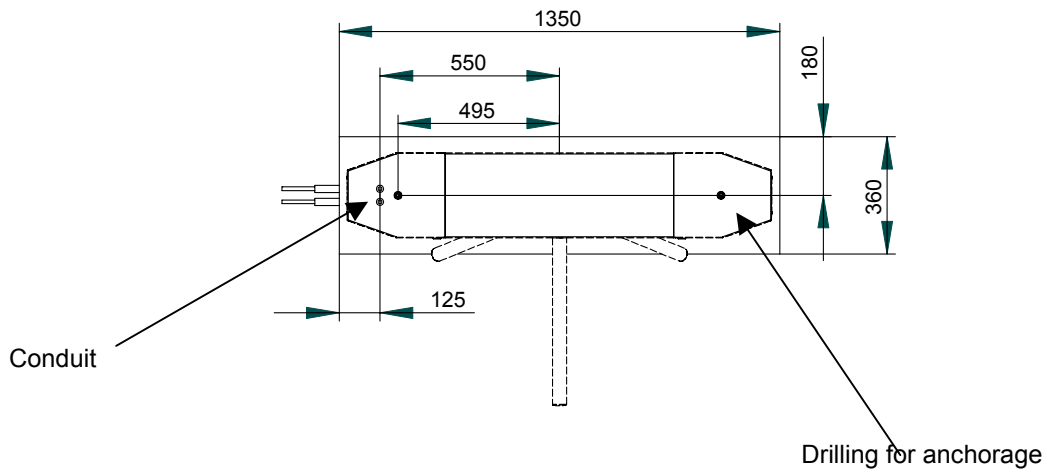

Fig. 2
Foundation

- 1 Plane level concrete mounting surface
- 2 Conduit(s) for data lines
- 3 Conduit(s) for feeder
- 4 Let the cable extend approx. 2 meters out of the conduits
- 5 Concrete PC250 or similar integrated heavy duty floor. If any floor covering (such as plates etc.) is used, make sure that the anchors grip into the foundation. (Probably longer anchors will be needed.) Outdoor foundations must be about 800 mm deep (frost depth) complete with steel reinforcement.

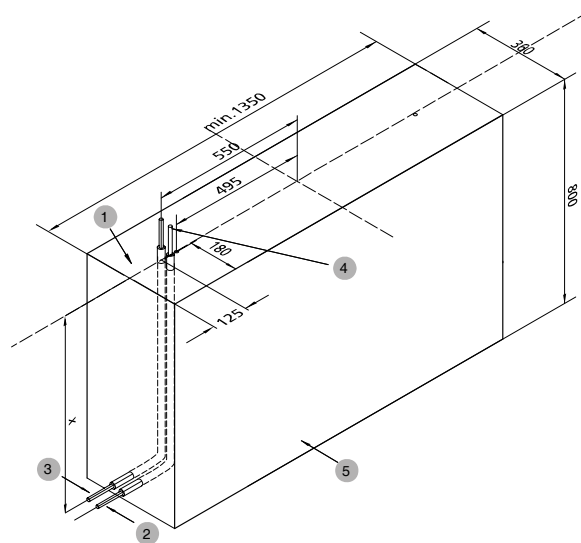

Fig. 3

5. Assembly and Installation

5.1 To Gain Access into the Barrier



Use the key provided to open the dust / waterproof hinged locked cover to gain access to the motor, drive and controller unit.

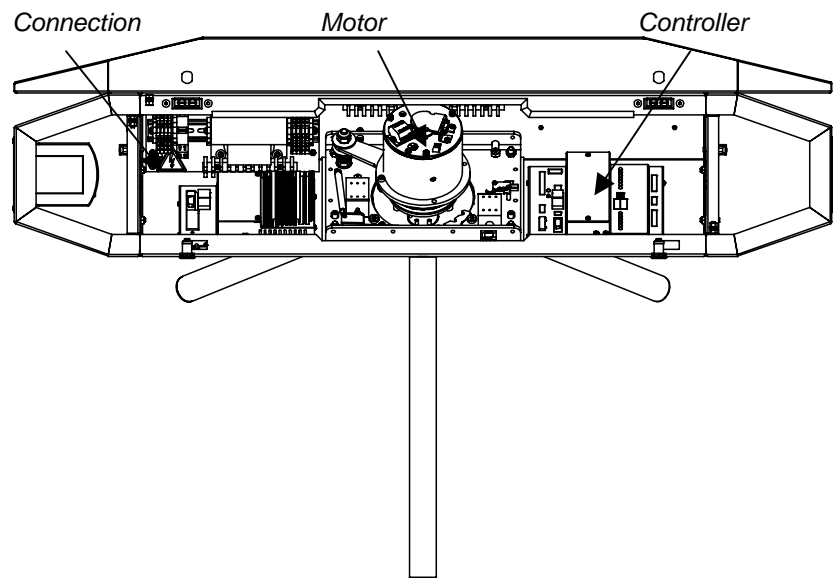

Fig. 4
Access to the connection,
drive unit and controller.

5.2 Mounting the Barrier Fixing Anchors

Refer to Fig. 5 for the method of mounting the barrier to the foundation using the two fixing anchors and the washers supplied. After final alignment the nuts must all be tightened.

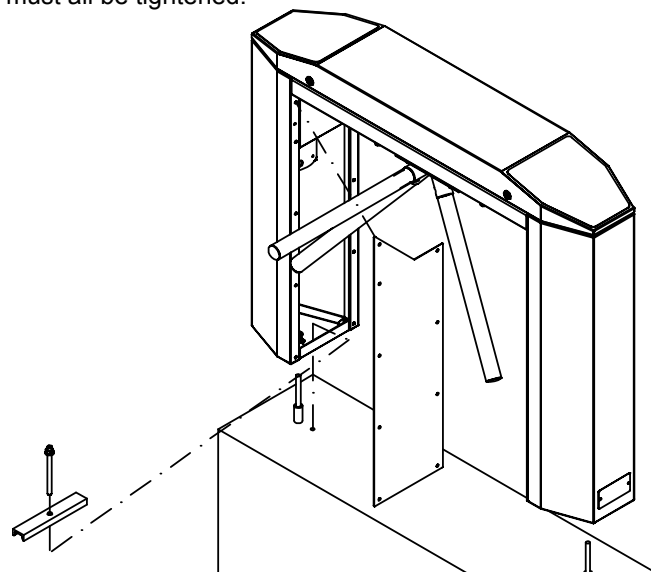

Fig. 5
Mounting the barrier fixing anchors



5.3 Mounting of the Turnstile Arms

The three turnstile arms are mounted to the capstan with each one screw (DIN912 M8x45). Tighten them with 36 Nm. Check them after a short operating time (approx. 1 week).

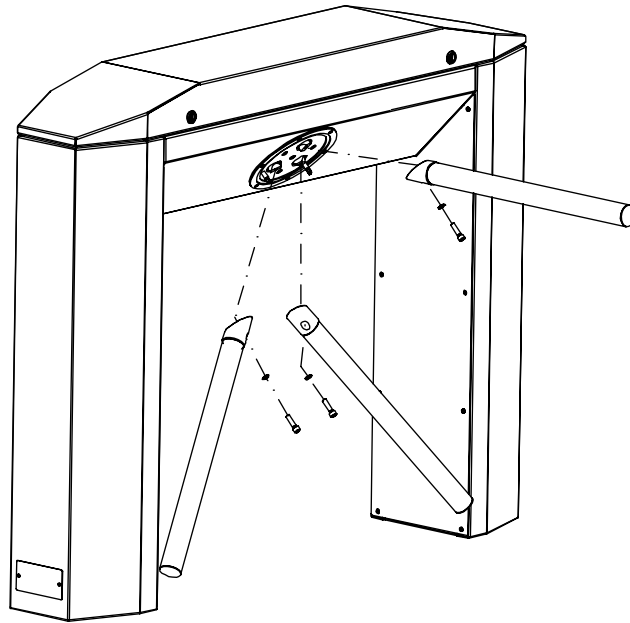
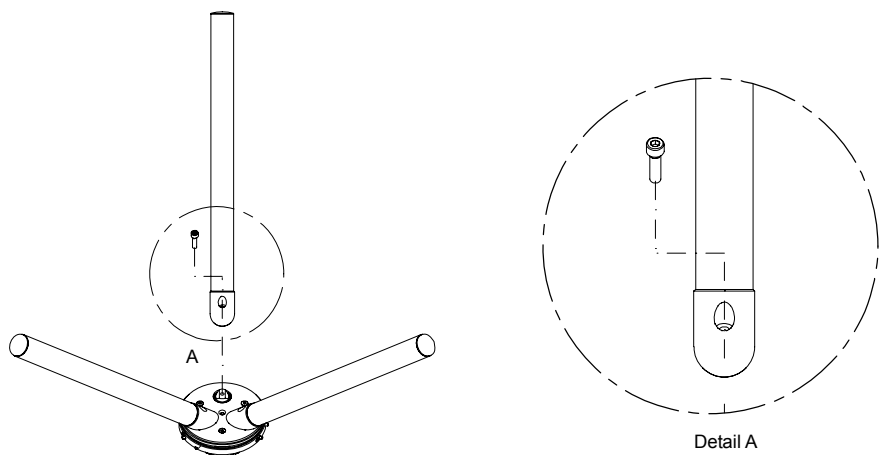

Fig. 6
Mounting of the turnstile arms



6. Electrical Connection

Incoming mains supply and connections should only be performed by a certified electrician.



Any access control systems may only be built in after consulting the manufacturer!

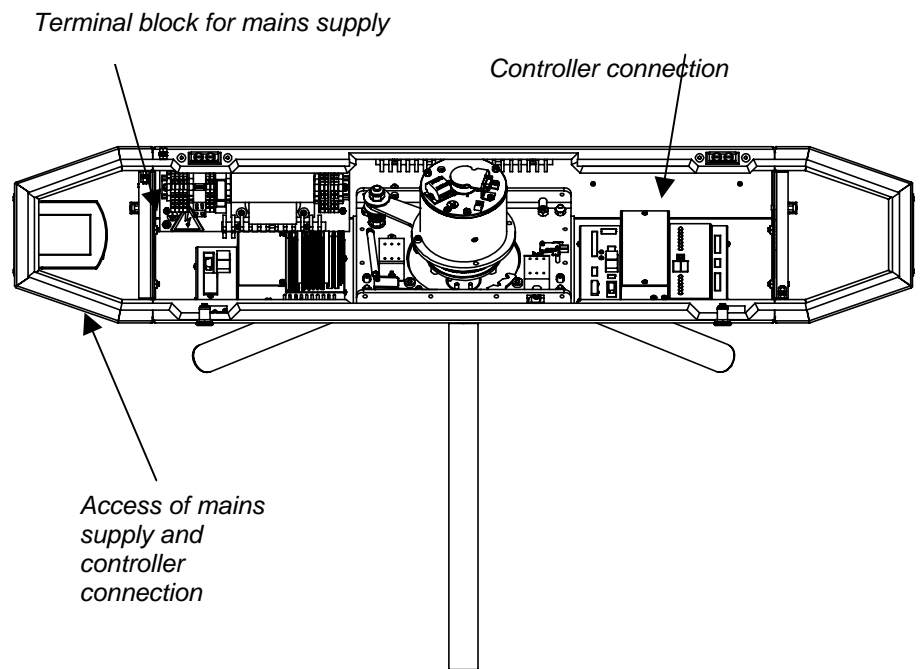

Please lead the incoming cables trough the housing in a professional way.

Fig. 7
Electrical schematic drawing

6.1 Wiring Diagram

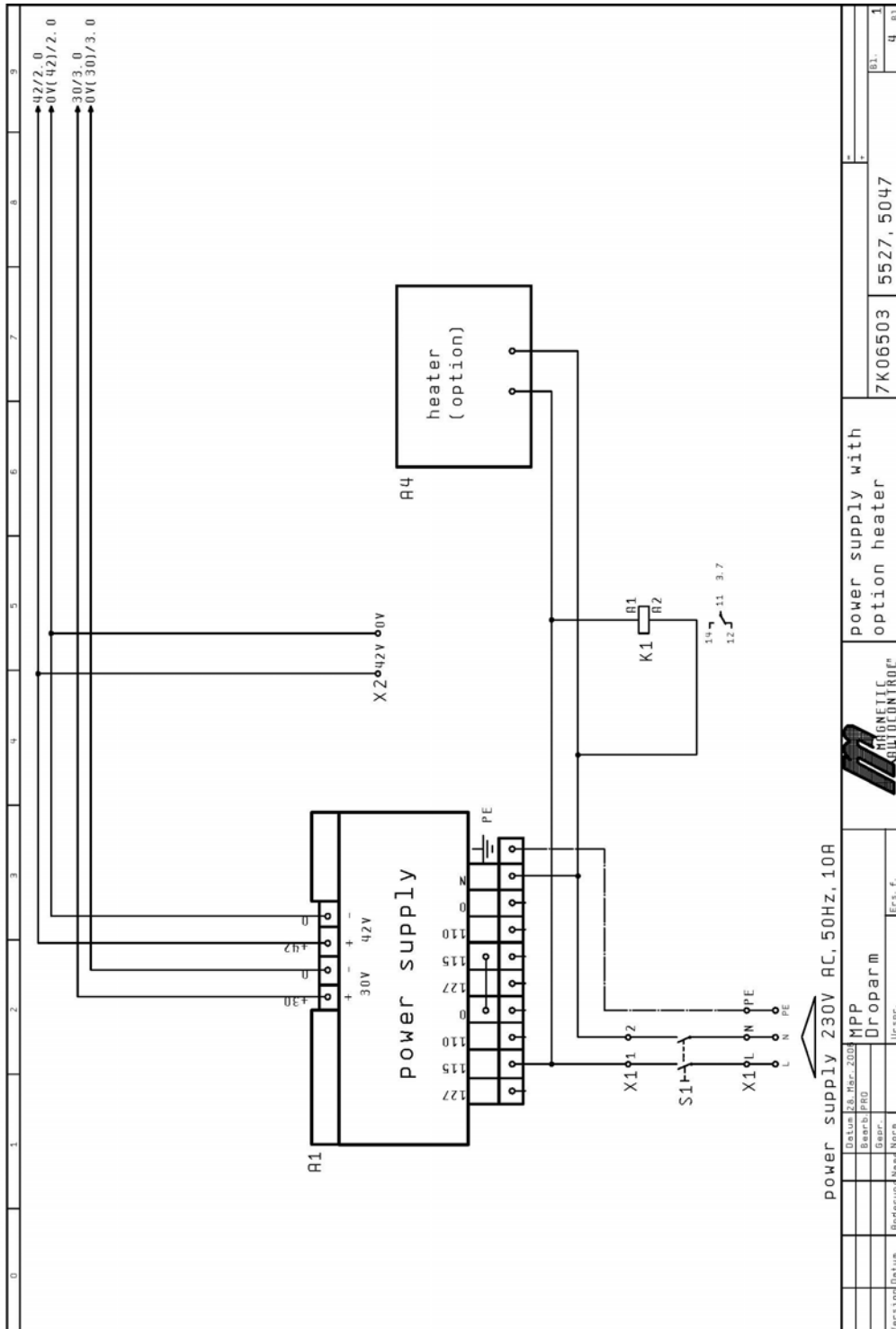
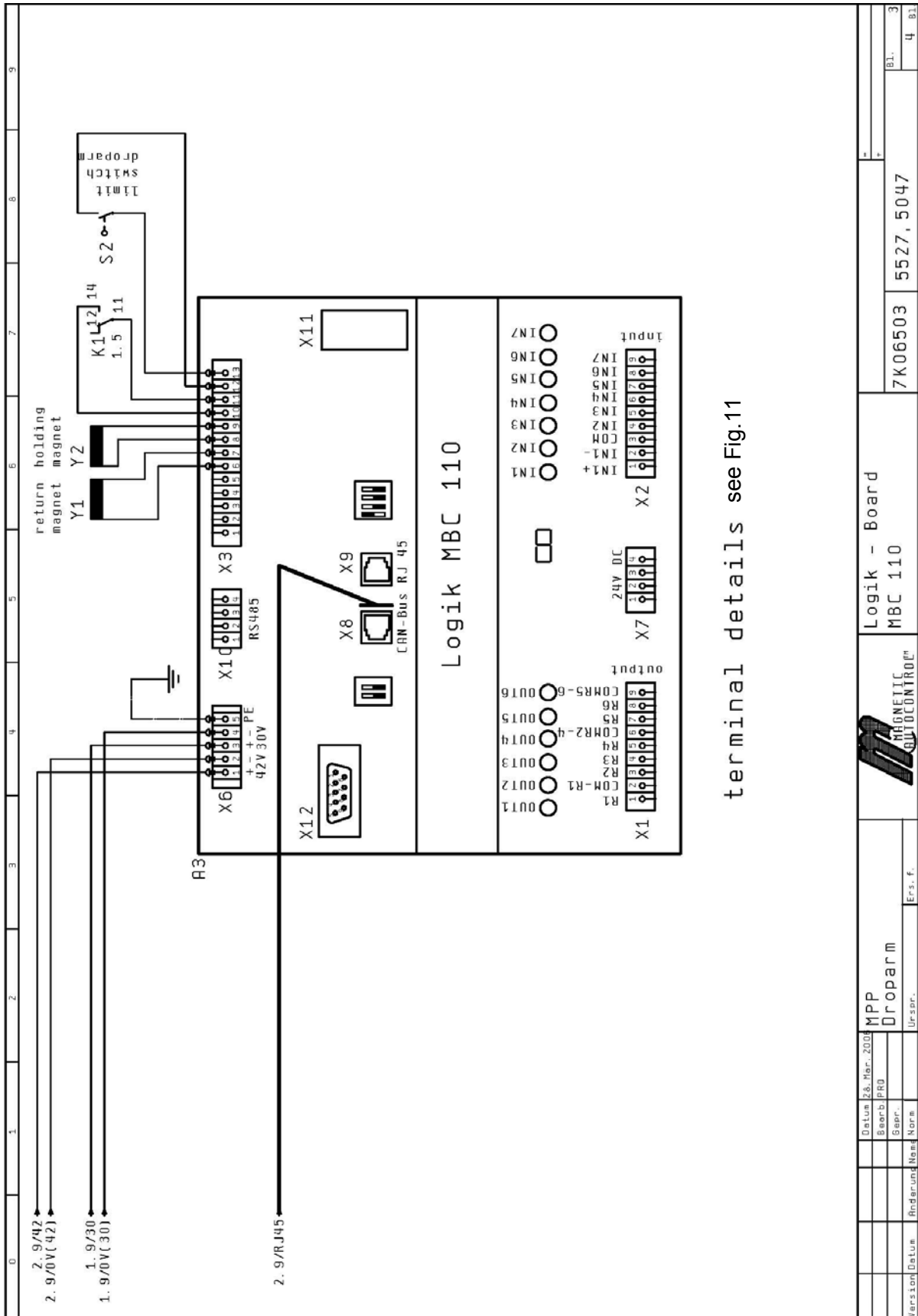

Fig. 8 Wiring diagram:
Please refer to Fig. 8 for electrical schematic drawing which details of all connections to the MBC controller.

Operating Instructions



terminal details see Fig.11

Destum (28. Mar. 2006)	MPP	Logik - Board	7K06503	5527, 5047	B1.	3
Beerb. PR0	Droptarm	MBC 110				
Gepr.	Ur-spr.	MAGNETIC AUTOCONTROL				
Version/Datum	Hersteller/Name Norm	Ers.- F.				

Fig. 10
Logic Board MBC 110

Operating Instructions

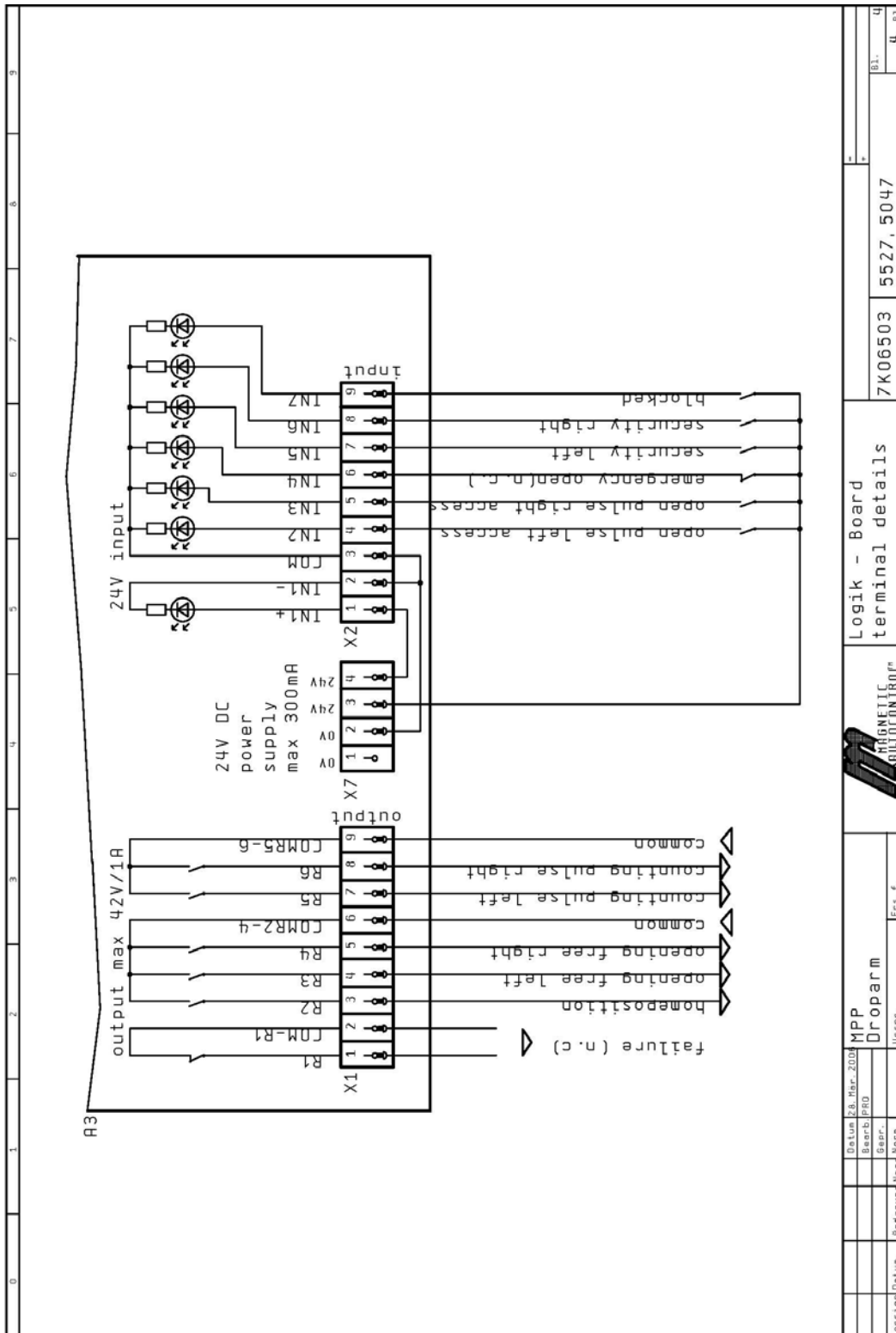
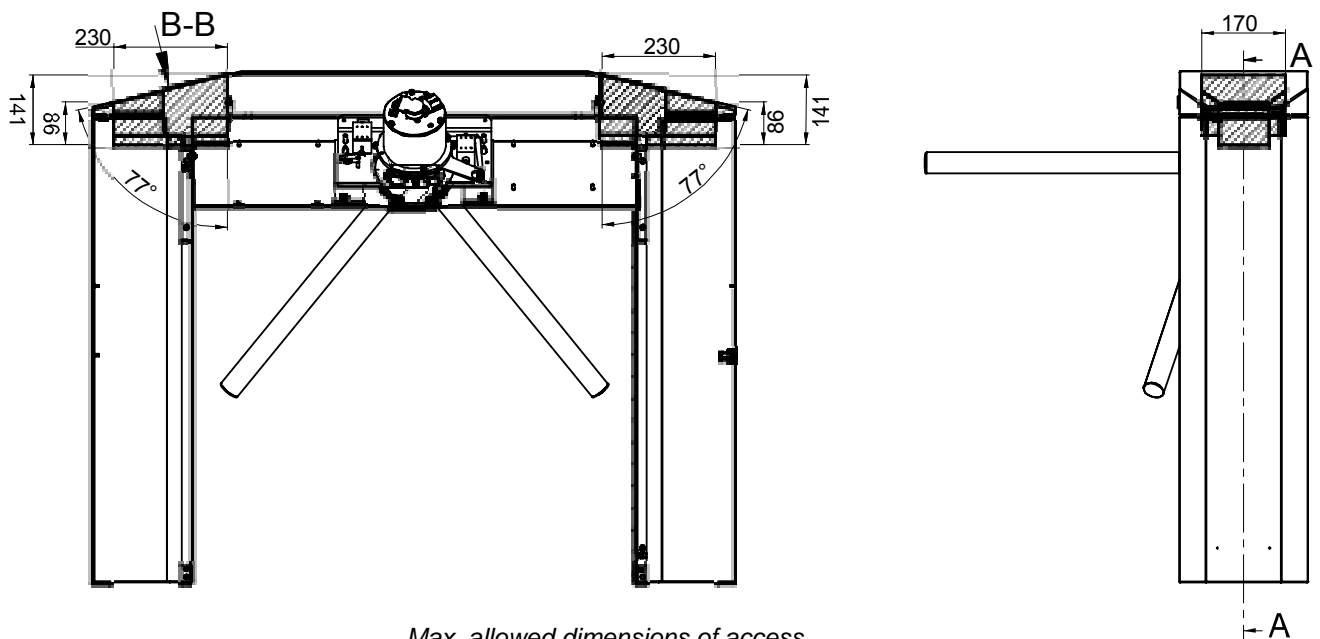

Fig. 11
Logic Board Terminal Details

7. Installation of Access Control Systems

It is possible to install access control systems at the both ends of the cover. The way of mounting those devices depends on the supplied cover. It can either be fixed with screws onto the surface of the standard cover. The optional available special cover is furnished with removable fascia panels made of stainless steel or a synthetic material for a more comfortable installation of any access control systems.



Max. allowed dimensions of access control devices

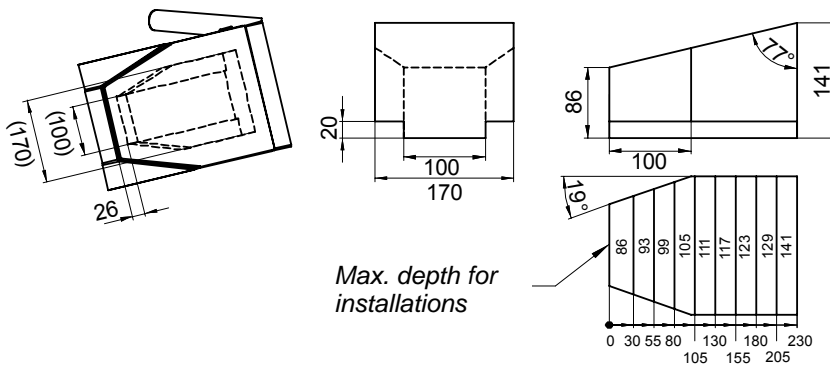

Fig. 12
Mounting of access control systems



8. Commissioning

Once the mechanical and electrical installation of the pivot barrier is completed, then it can be put into service. Check before start-up that all assembly and installation instructions have been followed and the electrical connections have been performed correctly.

As power is first supplied and the isolating circuit breaker is turned on, the torque drive turns the pivot arm to the next home position.

The barrier is then ready for operation

8.1 Drop Arm Function

In case of power failure or on receipt of an input signal the turnstile arm automatically turns down and allows free passage. Retracting of the turnstile arm will also be effected automatically after power return. (Please refer to chapter 3.)

9. Technical Support

Should faults occur that cannot be rectified by a technician, please contact our Technical Support that is available to you:

Phone + 49 07622/695-5

Please refer to the name plate on the pivot barrier housing for the data required in the case of queries. This is found on the inside of the unit vis-à-vis the MBC controller.

10. Spare Parts and Accessories

An exploded drawing which details the individual parts and their identification numbers is available on request.

11. Warranty

The manufacturer reserves the right to adapt to technological progress without special announcement.

Magnetic will be pleased to provide up to date information and possible changes or additions to the operating instructions on demand.

Under the precondition that the operating conditions are complied with and no inadmissible interventions have been made to the interior of the equipment and the equipment has no mechanical damage, a warranty of 3 years after delivery of the equipment or 2 years from date of the first start-up applies on all mechanical and electrical components.

12. Operating Instructions MBC-110A-F100 Controller

General Description:

The MBC controller was designed by Magnetic for special applications in their own products. The MPP pivot barrier can only be controlled together with the servo controller MMC-120-100/200.

The motor (MHTM) and sensor are wired directly to the MMC that is connected with the MBC controller via CAN BUS. (Please refer to the electrical schematic drawing.)

As our aim was to provide a customer-friendly handling of the controller, the MBC controller comprehends an internal and an external (customer-sided) connection side.

The customers connection side consists of :

1. DIP switch board (8/16 DIP switches)
2. 7 Digits display
3. 6 LED green for outputs
4. 7 LED red for inputs
5. Three encoded / pluggable terminal blocks Input / Output for being connected

12.1 DIP Switch Description of Parameter setting

Functions to be set by the customer

It is to distinguish between parameters that are set as default (factory setting only) and functions that can be adjusted at the controller via the control elements by the customer.

The following functions can be adjusted by the customer:

12.1.1 DIP-switch 1: Pulse Storage

If the pulse storage is switched off, the pedestrian pivot will be opened due to a pulse released at one of the both opening inputs. Any following pulses will be ignored as long the pedestrian pivot remains still open.

If the pulse storage is activated, several opening pulses can be stored. The pedestrian pivot stays open, until all stored pulses are executed and the pulse store is cleared. Each passage will reduce the pulse by 1.

DIP 1	Pulse Storage
OFF	No pulse stored
ON	Max. 5 pulses per pivot direction can be stored

The pulse storage is available with different operating modes that are to be set by the factory. (See chapter factory setting of parameters.)

12.1.2 DIP-switch 2: Buzzer

The buzzer is an acoustic alarm signal. A permanent alarm signal indicates the homing mode of the controller, passage in wrong direction or error of the controller.

An additional sound can be switched on for confirmation of a valid request.

DIP 2	Buzzer
OFF	Confirmation sound off
ON	Confirmation sound on

12.1.3 DIP-switch 3: Drop Arm

The controller must be informed, whether the pedestrian pivot is operated with or without a drop arm, as this has an effect especially on the operational sequences of the homing mode.

DIP 3	Drop arm
OFF	Without drop arm
ON	With drop arm

12.1.4 DIP switch 4: Indication Free Passage Indicated by a Short Movement of the Pivot Arm

If this function is activated, a short movement of the pivot arm (approx. 10 mm) indicates, that the signal of the card reader was accepted and processed und thus, free passage is released.

DIP 4	Indication Free Passage
OFF	Indication off
ON	Indication on

(Note: This function will be available not before mid 2006.)

12.1.5 DIP switch 5 and 6: Hold-Open Time

The hold-open time is a defined period during the turnstile is ready for passage after receipt of an opening pulse and nobody enters for passage. After expire of this period the pedestrian pivot locks (if nobody passed).

The hold-open time can be adjusted at 4 levels:

DIP 5	DIP6	Hold-Open Time
OFF	OFF	10 s
OFF	ON	20 s
ON	OFF	30 s
ON	ON	Endless

At level 4 "endless", the hold open time does not count down, the turnstile remains ready for passage.

12.1.6 DIP switch 7: Request of the Software Update Version

If this function is requested during operation mode, the update version is indicated in circular mode at the 7 segment display.

DIP 7	Update Version Software
OFF	Operating mode display
ON	Update Version displayed

12.1.7 DIP switch 8: Home Position

Required for alignment of the home position to the controller (see chapter "3.1.2 Learning of home-position").

DIP 7	Update Version Software
OFF	Normal operating mode
ON	Disposed to learn

12.1.8 DIP switch 9 and 10: Program-Mode

The selected program mode determines the controller program that runs after power return and reset of the controller.

DIP 9	DIP10	Program Mode
OFF	OFF	MPP Standard
OFF	ON	Reserve
ON	OFF	Reserve
ON	ON	Reserve

(Note: This will be used for future projects. At present, please choose MPP standard.

12.1.9 DIP switch 11: Manual Reset

It can be switched between reset via IN "manual reset" and "auto-reset" via DIP switch 11.

Manual Reset

After restart of the controller (power failure), first, the IN "manual reset" must be confirmed to enable the controller to go into operation.

Auto-Reset

With auto-reset the pedestrian pivot automatically goes into operation.

DIP11	Reset
OFF	Auto-Reset
ON	Manual Reset

12.1.10 DIP switch 12: Security Level

This function is only available with the MPP (Magnetic Pedestrian Pivot) and MPT (Magnetic Pedestrian Turnstile) barriers.

It defines the behavior of the brake in the event of several attempts to pass in wrong direction.

Security Low

It is possible, to pass in wrong direction by several steps. After recognition of wrong direction, though the brake will be activated but released immediately. If just in this moment the pivot arm is pushed down, it can be moved a little until the brake is activated again.

If the controller recognizes at release of the brake, that no further attempt is made to push the pivot arm, the motor returns to primary home position.

Security High

The holding time until the brake will be released after a wrong direction attempt will increase progressive with rising angle.

If the controller recognizes at release of the brake, that no further attempt is made to push the pivot arm, the pivot arm returns to the next home position.

DIP 12	Security
OFF	Security low
ON	Security high

12.1.11 DIP switch 13 - 16: Reserve

These DIP switches are designed for future applications.

DIP 13 - 16	Lock LH
OFF	Not engaged
ON	Not engaged

The actual version of the MBC controller disposes of 8 DIP switches, hence only these DIP switches can be adjusted. (All following DIP switches are planned for the future.)

12.2 Seven Digits Display for Diagnosis

12.2.1 Function of the Diagnostics Display

The 7 digits display is designed for purpose of convenient diagnostics, showing different operational states and errors.

12.2.2 Normal Operating Status

Indication by a permanent blinking segment with 0.5 Hz (defined in "fry_op")

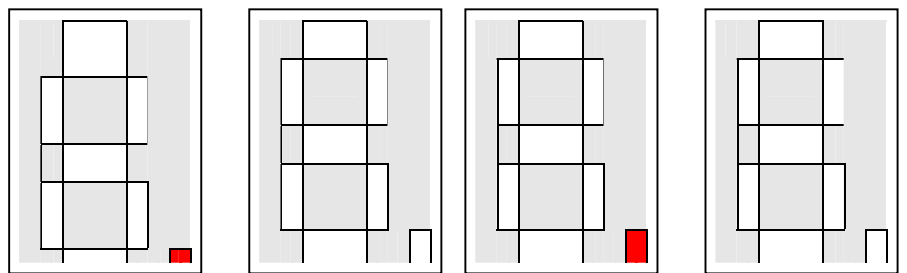

12.2.3 Learning of Home Position

Permanent illuminated segments in the shape of an H until the home-position was confirmed via DIP switch, then the normal operating status is displayed.

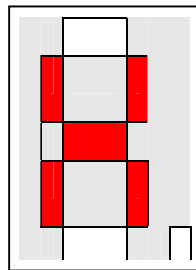

For initial learning or change of the home position, make sure, that the power is OFF. Set DIP8 ON. Switch ON the main power of the MPP. (Now the MBC displays an H.) Re-position the turnstile arm in the desired final position by hand. Switch DIP 8 OFF. Once again, switch the MPP OFF and re-boot it.

12.2.4 Homing (Turnstile Arm Moves to Home Position)

Blinking segments at 1 Hz frequency (defined in "fry_home") in the shape of an H indicate when the drop arm approaches to the home-position. As soon as the home-position is reached, normal operating status is displayed.

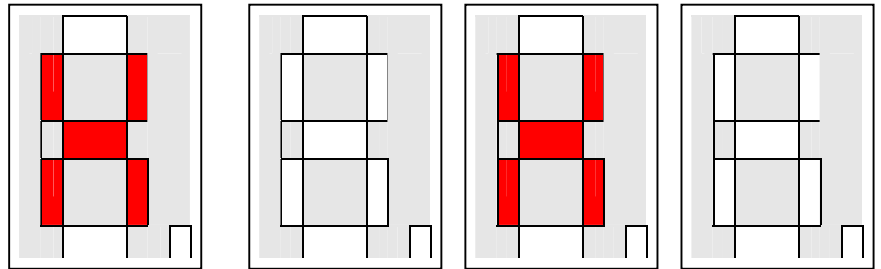

12.2.5 Waiting for Manual Reset

A white bar rotates clockwise until a reset signal is activated, then normal operating status is displayed. Each status is displayed during 0,5 seconds (defined in "delay_mes").

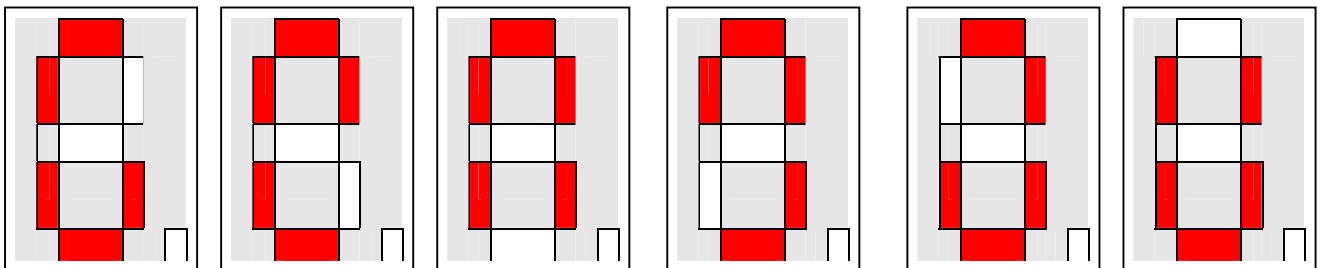

12.2.6 Display Update Version of the Software

First, the character *U* is displayed, successively followed by the major release (with a dot), the minor release and at last a pause, recurring in repeated sequences. Each status is displayed during 2 seconds (defined in "delay_mes").

Example for version status 1.4

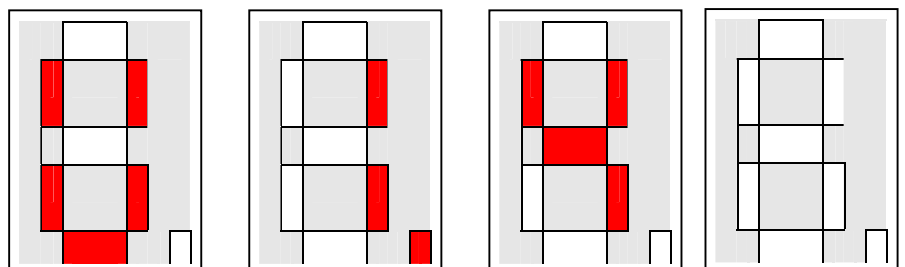

12.2.7 Display Error Code

First, the character *E* (Error) is displayed, successively followed by the first number, and then the second number of the error code and at last a pause, recurring in sequences. Each status is displayed during 2 seconds (defined in "delay_mes").

Example for error code 23

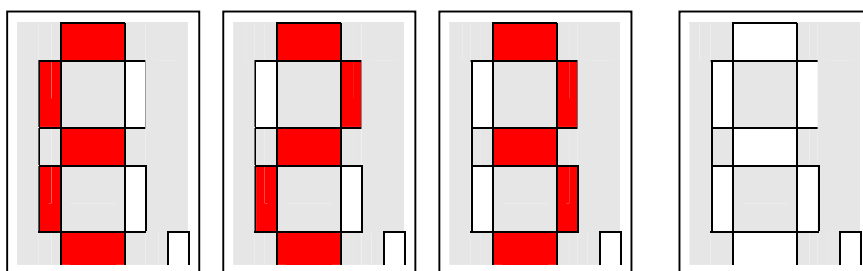

Legend Error Code:

Error Code	Description	Automatic Reset Function
01	Operating time control	Yes
02	Emergency access activated	Yes
03	Breach control activated	Yes
04	Contact mat energized	Yes
05	Access attempt wrong direction	Yes
06	Drop arm magnet currentless	No
07	Recognition vandalism	
08	Reserve	
09	Reserve	
10 - 19	Reserve	
20 - 39	Software failure (still to define)	No
40 - 59	Hardware failure (still to define)	No
60 - 79	Communication failure (still to define)	No
80 - 99	Reserve	

All those status and error codes, that are with automatic reset function, will be displayed during a period of max. 10 minutes after the error is rectified but however, as long as the failure is existing.

All other errors will cause pedestrian pivot barriers to be set out of operation. The error code will be displayed permanently until new start of the controller after rectification of the fault.

12.2.8 LED Green

The LED indicate, which outputs have been activated by the controller. Each LED is assigned to the according output (i. e. output 6 is assigned to LED 6 etc.).

12.2.9 LED Red

The LED indicate, which inputs have been activated by the controller. Each LED is assigned to the according input (i. e. input 6 is assigned to LED 6 etc.).

12.3 Functions of the Inputs

(Please refer to the wiring diagram)

Default setting of the inputs

INPUT	Default Function
IN1	ASB signal for servo controller (hard-coded)
IN2	Opening passage direction LH
IN3	Opening passage direction RH
IN4	Emergency entrance (attempt to reach the next end position)
IN5	Surveillance LH / Protection against breach
IN6	Surveillance RH / Recognition of illegal passage by means of a contact mat
IN7	Lock of the pedestrian pivot
IN8	End Stop of drop arm disabled
IN9	Recognition power failure (of main power)

The inputs can be operated either with 24V or even with 0V (high active or low active).

The function of IN1 can not be changed because of the input is hardware-sided connected with the ASB-input of the servo's final stage(s).

Release of the servo controller via IN1. The logic is inverted (recognition of broken wire), i. e. the controller is only energized in case of an permanent contact is activated. Otherwise the motor will be currentless and the drop arm magnet will release (if existing).

IN2 up to IN9 can be used for other functions via a parameter set.

Operating Instructions

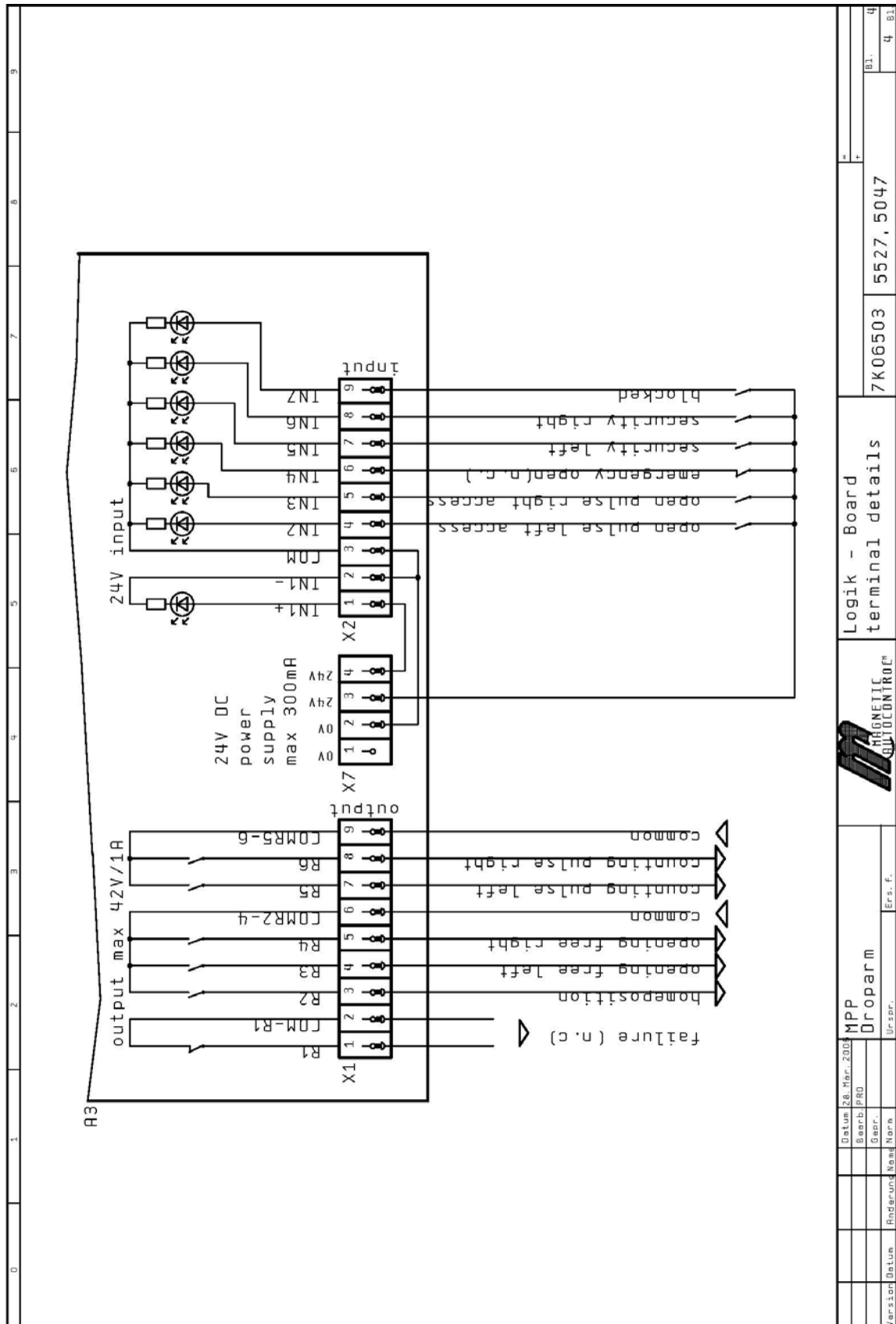

Datum: 28. Mar. 2006		MPP		7K06503		5527, 5047	
Saarb. PRO		Droparam		Logik - Board		terminal details	
Version: Datum		Ersterr.		MAGNETIC AUTOCONTROL		B1.	
Ersterr. Nord		Ersterr.		Ersterr.		4	
Ersterr. Nord		Ersterr.		Ersterr.		4	
Ersterr. Nord		Ersterr.		Ersterr.		4	
Ersterr. Nord		Ersterr.		Ersterr.		4	

Fig. 13

12.3.1 Functional Description of the Inputs

Note: The function of IN1 can not be changed because of the input is hardware-sided connected with the ASB-input of the servo's final stage(s).

12.3.1.1. Input 2 Function Opening Pulse/Signal Aisle LH

Opening pulse for entry / left hand passage.

In the event of the signal is activated more than 5 seconds, a permanent contact is set.

12.3.1.2. Input 3 Function Opening Pulse/Signal Aisle RH

Opening pulse for exit / right hand passage.

In the event of the signal is activated more than 5 seconds, a permanent contact is set.

12.3.1.3. Input 4 Function

Free passage in both direction in case of emergency. Drop arm turns down automatically.

12.3.1.4. Input 5 Function Safety LH

Wiring of a monitoring system for recognition of a fraudulent access attempt by breach.

12.3.1.5. Input 6 Function Safety RH

Wiring of a monitoring system for recognition of a fraudulent access attempt by breach.

12.3.1.6. Input 7 Function Locked Gate

Input for lock of the pedestrian pivot in both directions. Any subsequent opening pulses will not be accepted then, despite a pulse is given by the higher ranking IN1 (emergency). In this case the locked barrier can released for free exit /entry.

12.3.1.7. Inputs 8 und 9 are for internal use.

12.4 Hardware of the Relay Outputs

The relay outputs REL1 to REL6 are wired on a shared connection plug board. Groups are combined to a pool in order to save terminal clamps.

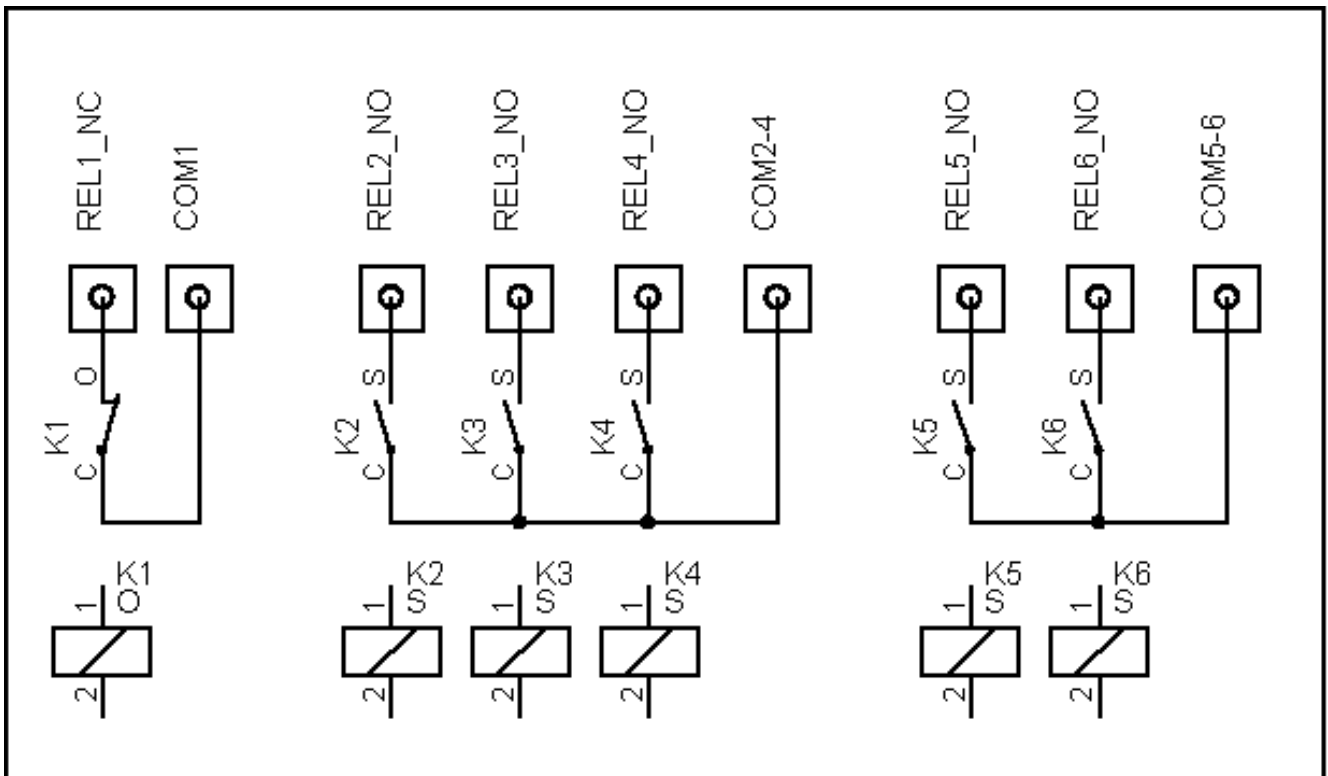

Fig. 14
Wiring Diagram Relay OUTPUTS (simplified drawing)

12.4.1 Possible Output Functions

Note: The function of REL1 can not be changed because of the output is also engaged for feedback in the event of power failure.

Output	Default Function
Relay 1	Collective fault / Power failure
Relay 2	Pedestrian Pivot in idle position
Relay 3	Free passage LH
Relay 4	Free passage RH
Relay 5	Counter pulse LH
Relay 6	Counter pulse RH
MOSFET-Output 1	Controlling holding solenoid drop arm
MOSFET-Output 2	Controlling retracting solenoid drop arm
MOSFET-Output 3	Heartbeat
MOSFET-Output 4	Reserve

Relay performance data max. 42V/1A

12.4.1.1. REL1 = Collective Errors and Alarm Outputs

In case of certain errors arise, a signal is activated via REL1 and stays active as long the error is pending.

Possible failures might be:

1. Running time of the MPP too long = obstacle recognized
2. Manual reset expected
3. Magnet of drop arm currentless = aisle open
4. Emergency open activated (inverted -> no signal pending)
5. Protection against breach activated
6. Contact mat energized
7. Failure between CAN communication and the final stage
8. Hardware failure final stage
9. Software failure final stage
10. Power failure

Important Information:

A power failure is to indicate at the collective output. For this reason, REL1 is operated inverted. From this it follows, that the relay is activated as long no failure occurs. As soon as one of the above mentioned collective errors arise, the relay will release.

12.4.1.2. Relay 2 Function Pedestrian Pivot in Home Position

A permanent contact is activated via this output as long as the pedestrian pivot is in home position.

12.4.1.3. Relay 3 Function Display free passage LH

A signal is activated via this output in case of free passage at left hand direction. This output can also be used to lock the pulse transmitter for right hand passage, if left hand passage is released.

12.4.1.4. Relay 4 Function Display free passage RH

A signal is activated via this output in case of free passage at right hand direction. This output can also be used to lock the pulse transmitter for left hand passage, if right hand passage is released.

12.4.1.5. Relay 5 Function Counter LH

A counter pulse is given via this output when the end position is reached after passing in left hand direction. This is also true for permanent open mode.

12.4.1.6. Relay 6 Function Counter RH

A counter pulse is given via this output when the end position is reached after passing in right hand direction. This is also true for permanent open mode.

13. Controller MMC-120-200

The MMC controller has been wired and adjusted und left the factory in a fully operational condition. Other adjustments are not possible by default. The DIP switches are for scheduling the CAN Bus and cannot be changed.

Conversions and modifications to the control module are not permitted. If, at any time you require to replace this controller (e. g. in case of repair) please arrange the terms of replacement with Magnetic before as otherwise any liability and warranty is declined by the manufacturer.

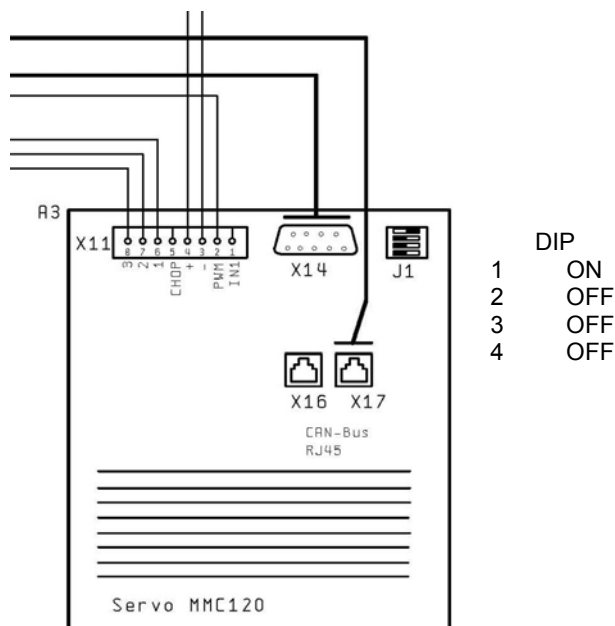

Fig. 15



Manufacturer

Magnetic Autocontrol GmbH.
 Grienmatt 20
 D-79650 Schopfheim
 Phone 07622/695-5
 Fax 07622/695-603
 e-mail: info@ac-magnetic.de
 www.ac-magnetic.com